



Deckbake 450 1T Master Pro H14

Electrical Supply

CODE: 925949410

Trays	1T 40x60 cm
Internal dimensions	630 L x 630 P x 140 H mm
Outside dimension	1000 L x 942 P x 386 H mm
Power	4,5 kW
Weight	76 Kg
Max temperature	350° C
Power supply	400 V ~ 3PH + N + PE 400 V ~ 2PH + N + PE 230 V ~ 3PH + PE 230 V ~ 1PH + N + PE 50-60 Hz

Equipment

Double low emissive glass	High-performance thermal insulation	Modularity
CE Certificate	Temperature control top / bottom in °C	Door gasket in refractory material
Time-programmable steam injection	Manual steam injection	Manual mode
Automatic preheating	Delayed start programming	Automatic detection and errors report
Overlap option	Ground in refractory "pink" stone	

Options

Ethernet connection and wi-fi set-up DeckNET	Steamer and automatic chimney
--	-------------------------------

Deckbake 450 1T Master Pro H14

Electrical Supply

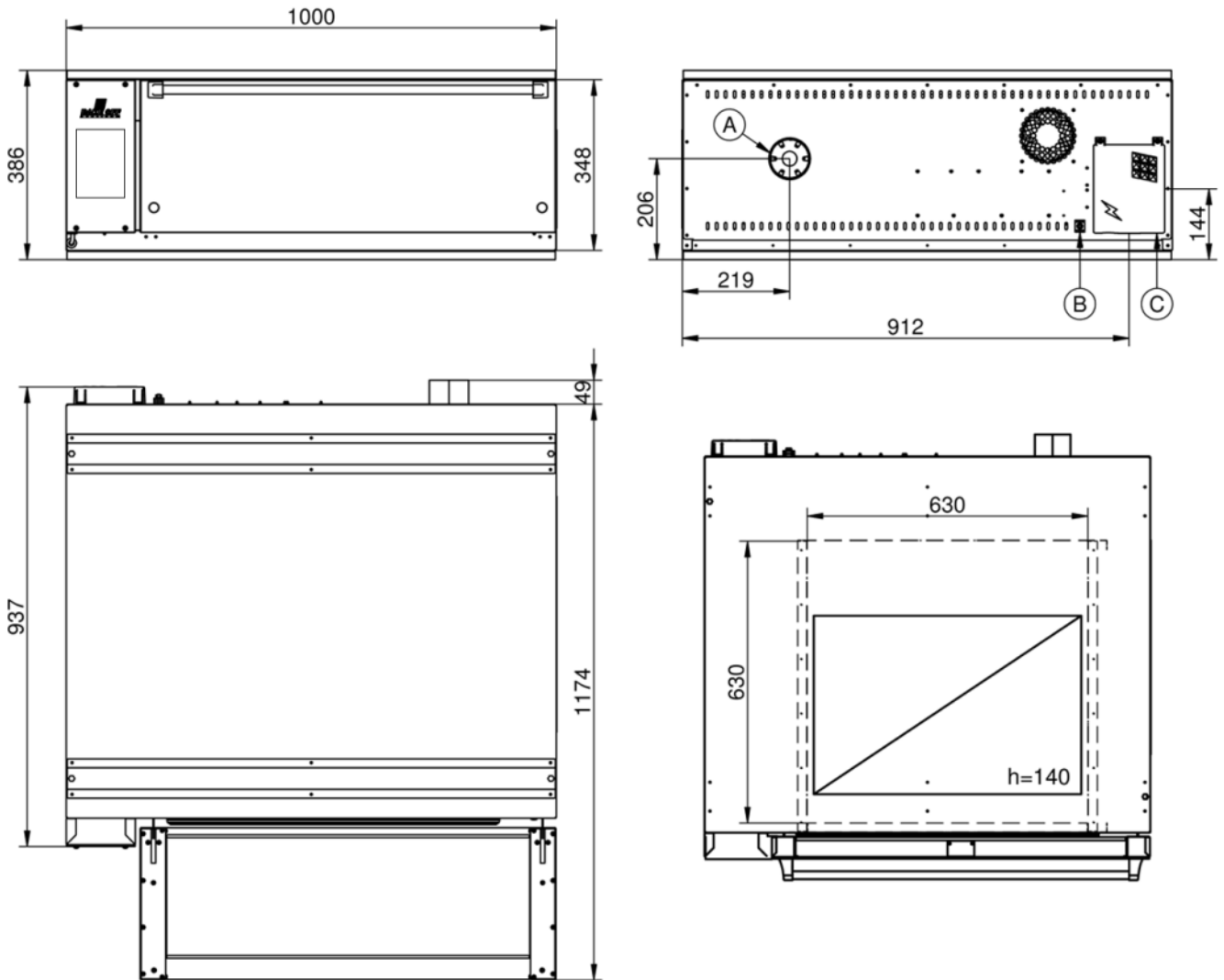

Legend

- A - Steam exhaust Ø 80
- B - Equipotential terminal comb
- C - Electric supply

Deckbake 450 1T Master Pro H14

Electrical Supply

Supply and Connections



Packaging

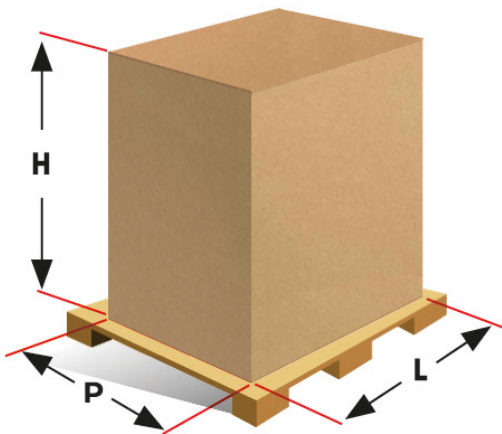

Packing size:	1100 L x 1070 P x 580 H mm
Net weight:	76 Kg
Gross weight:	93 Kg