



Bistrot 16T Classic

Electrical Supply

CODE: 925915320

Trays	16T 40x60 46x66 cm
Outside dimension	850 L x 963 P x 1860 H mm
Tray distance	80 mm
Power	32 kW
Weight	177 Kg
Max temperature	270° C
Power supply	400 V ~ 3PH + N + PE 400 V ~ 2PH + N + PE 230 V ~ 3PH + PE 230 V ~ 1PH + N + PE 50-60 Hz

Equipment

Led illumination	BakeAIR multi-fan system	Double low emissive glass
High-performance thermal insulation	Blue LED for chamber cleaning check	Five fan speeds and semi-static cooking
Nine cooking modes	Automatic chimney opening BakeDRY	Program blocking with password
Rounded baking chamber	CE Certificate	Automatic control of dry/steam balance inside the chamber
Steam control in percentage BakeSTEAM	Automatic control of the cooking level and load	Multi-timer function for multiple and mixed cooking
Storage, viewing* and exportation of cooking data (haccp)	Customized programs mode	Manual mode
Preset programs mode	Automatic preheating	Cooling program
Delayed start programming	Delayed cooking programming	Pre-loaded and online cookbook
Automatic detection and errors report	Openable inner glass for easy cleaning	Fan inversion, speed control and motor brake

Options

Heart probe MultiBakePOINT	BakeCLEAN automatic washing system	Safety rinse
Data logger for USB connection		

Bistrot 16T Classic

Electrical Supply

Supply and Connections

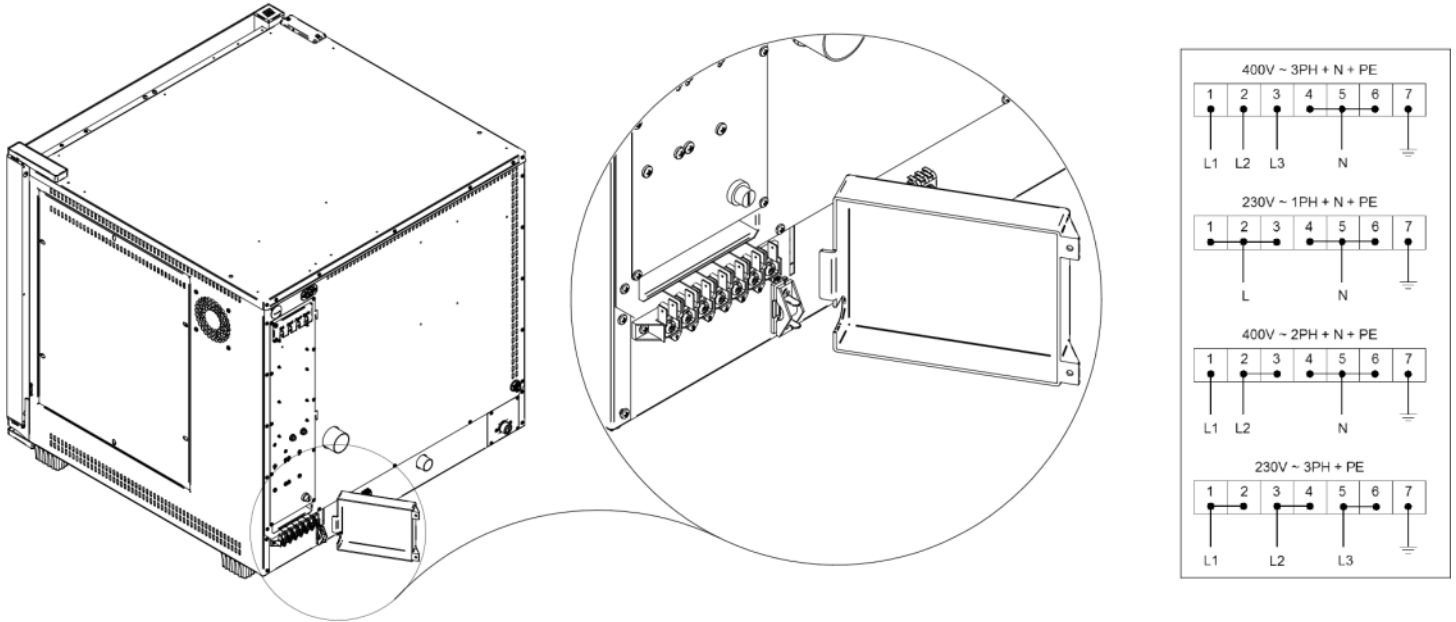

Packaging

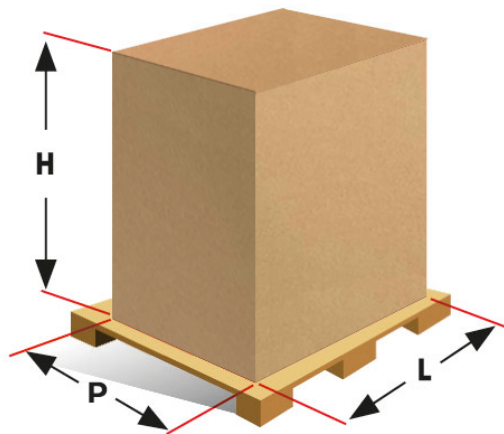

Packing size:	950 L x 1040 P x 2090 H mm
Net weight:	177 Kg
Gross weight:	233 Kg