



Easy 10T Manual

Electrical Supply

CODE: 925813120

Trays	10T GN1/1 - 10T 60x40 cm
Outside dimension	850 L x 915 P x 1150 H mm
Tray distance	80 mm
Power	16 kW
Weight	110 Kg
Max temperature	270° C
Power supply	400 V ~ 3PH + N + PE 400 V ~ 2PH + N + PE 230 V ~ 3PH + PE 230 V ~ 1PH + N + PE 50-60 Hz

Equipment

BakeAIR multi-fan system	Double low emissive glass	High-performance thermal insulation
Two fan speeds	Three cooking modes	Rounded baking chamber
Modularity	CE Certificate	Steam control in percentage BakeSTEAM
Manual mode	Overlap option	Openable inner glass for easy cleaning

Options

Left door opening

Easy 10T Manual

Electrical Supply

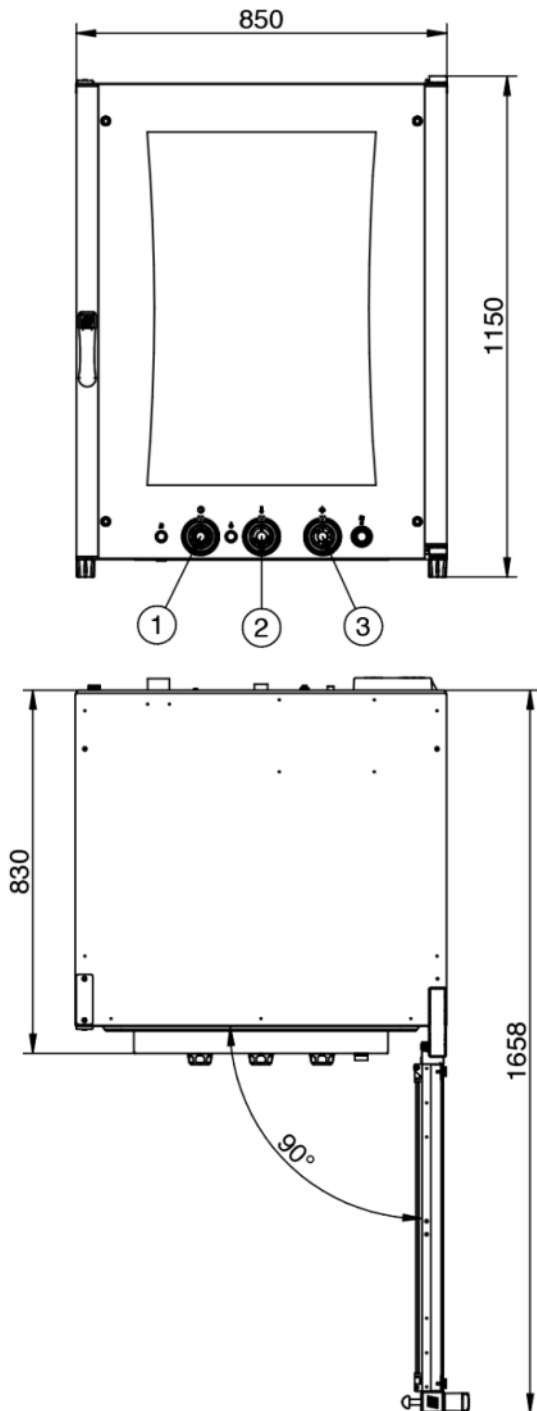

- 1 - Manopola Timer - Timer knob - Poignée de la minuterie - Mando del temporizador
 2 - Manopola temp. - Temp. knob - Poignée de la temp. - Mando de la temp.
 3 - Manopola Umidità - Humidity knob - Poignée de l'humidité - Mando humedad

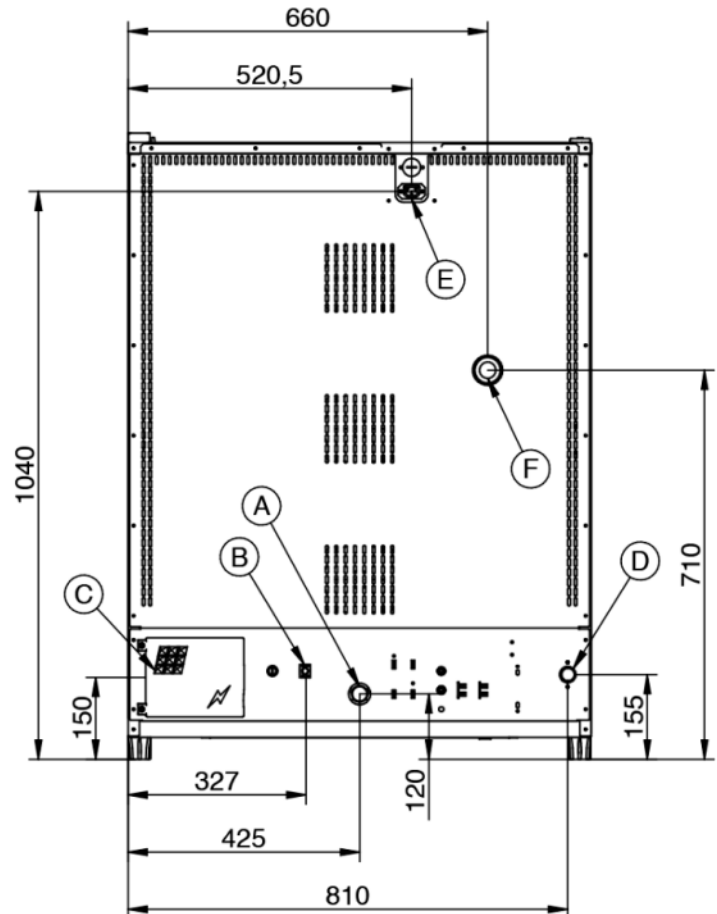

Legend

- A - Drain liquid Ø 30mm
 B - Equipotential terminal comb
 C - Electric supply
 D - Water inlet 3/4"
 E - Extracting hood supply
 F - Steam exhaust Ø 50mm

Easy 10T Manual

Electrical Supply

Supply and Connections

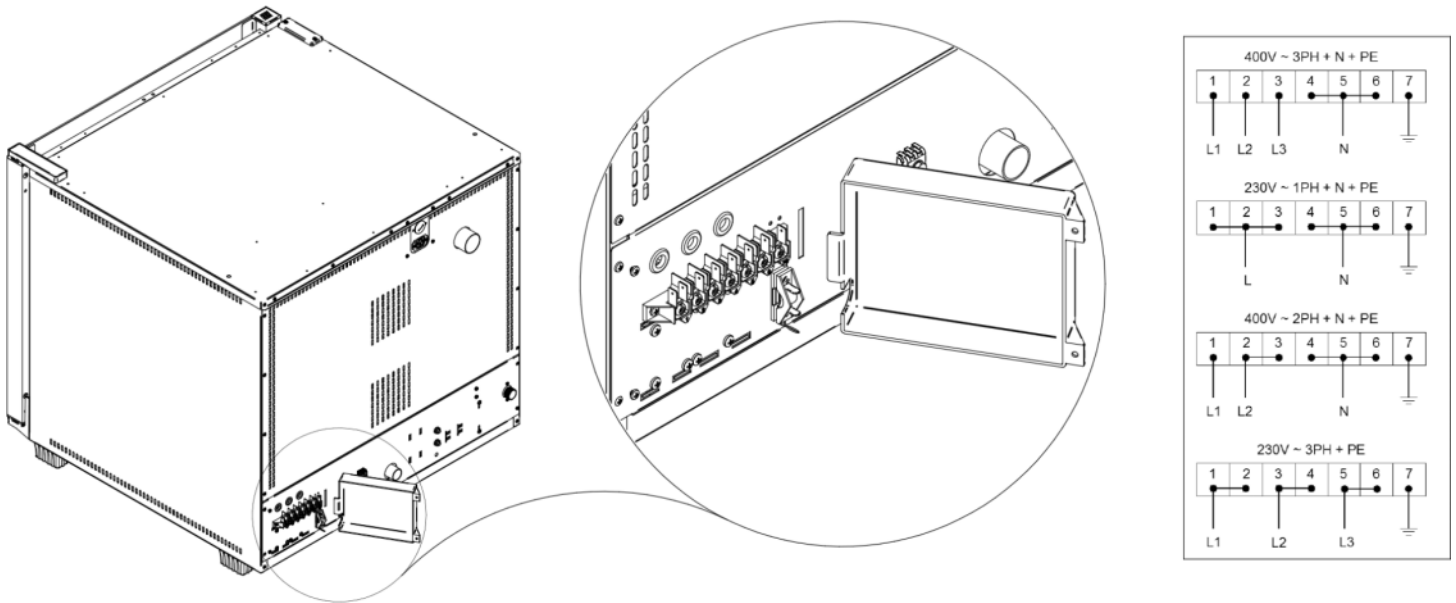

Packaging



Packing size:	920 L x 1000 P x 1300 H mm
Net weight:	110 Kg
Gross weight:	130 Kg