



Easy 4T Manual

Electrical Supply

CODE: 925804120

| | |
|-------------------|---|
| Trays | 4T GN1/1 - 4T 60x40 cm |
| Outside dimension | 830 L x 830 P x 570 H mm |
| Tray distance | 75 mm |
| Power | 8,5 kW |
| Weight | 56 Kg |
| Max temperature | 270° C |
| Power supply | 400 V ~ 3PH + N + PE 230 V ~ 3PH + PE 230 V ~ 1PH + N + PE 50-60 Hz |

Equipment

| | | |
|--------------------------|---------------------------|--|
| BakeAIR multi-fan system | Double low emissive glass | High-performance thermal insulation |
| Two fan speeds | Three cooking modes | Rounded baking chamber |
| Modularity | CE Certificate | Steam control in percentage BakeSTEAM |
| Manual mode | Overlap option | Openable inner glass for easy cleaning |

Options

Left door opening

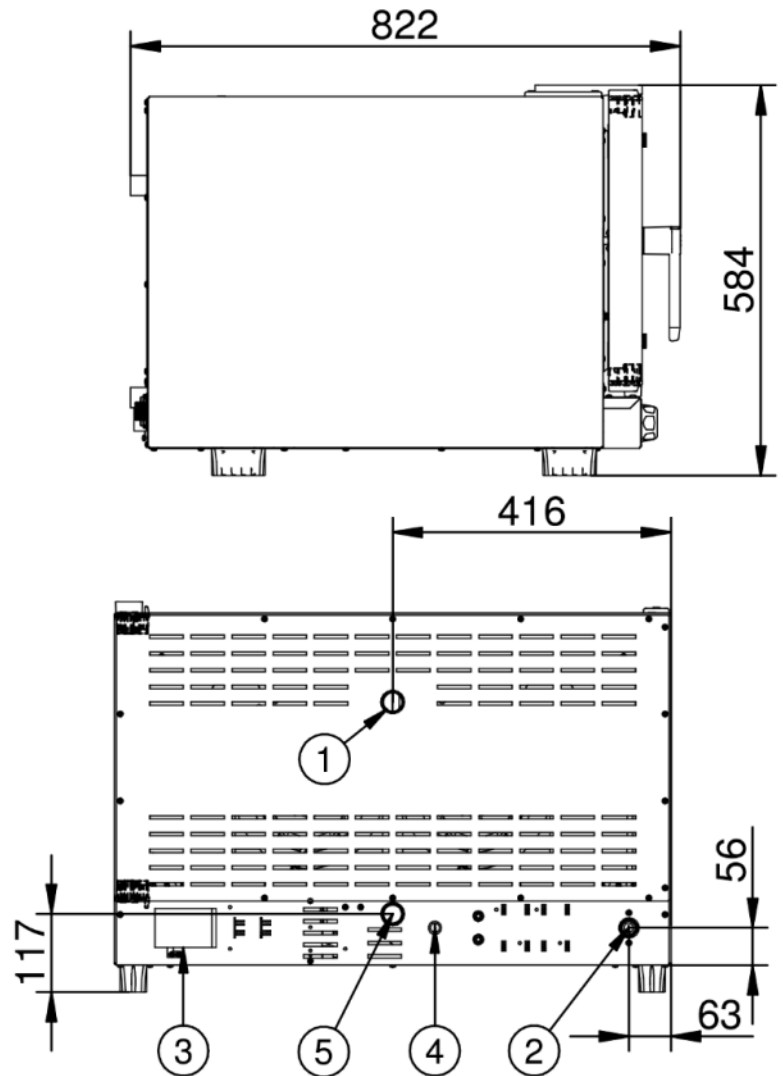
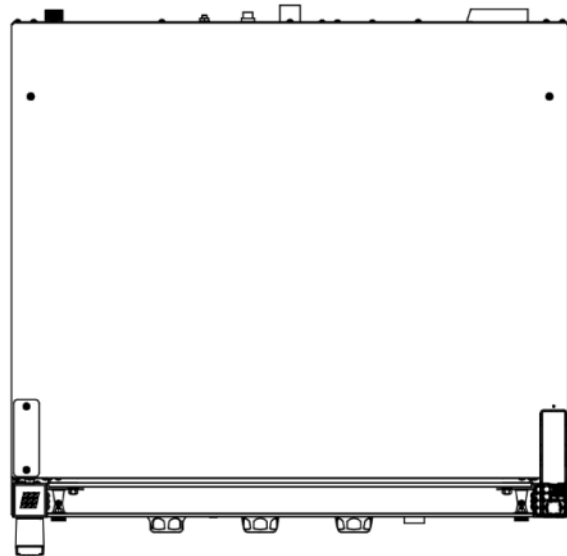
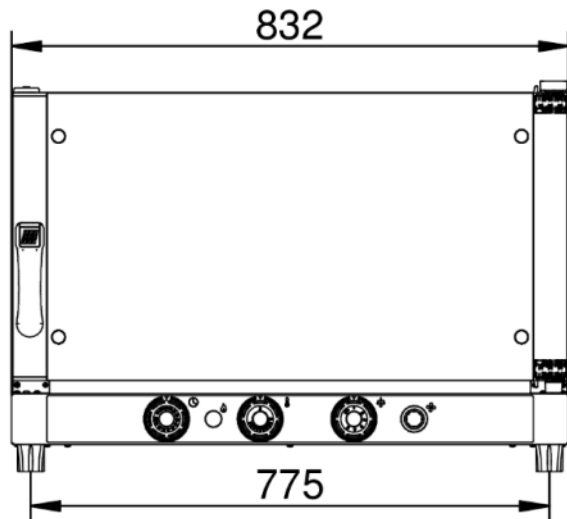

Legend

- 1 - Steam exhaust Ø 30mm
- 2 - Water inlet 3/4"
- 3 - Terminal box supply
- 4 - Safety thermostat
- 5 - Water exhaust Ø 30mm

Easy 4T Manual

Electrical Supply

Supply and Connections

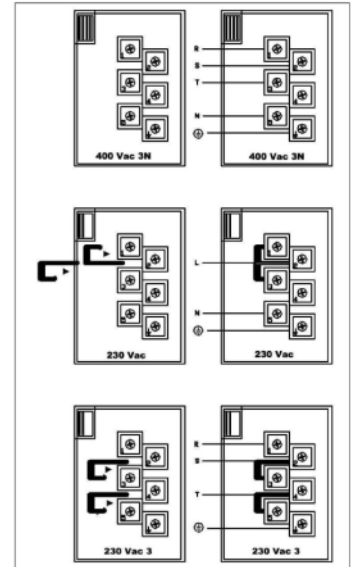
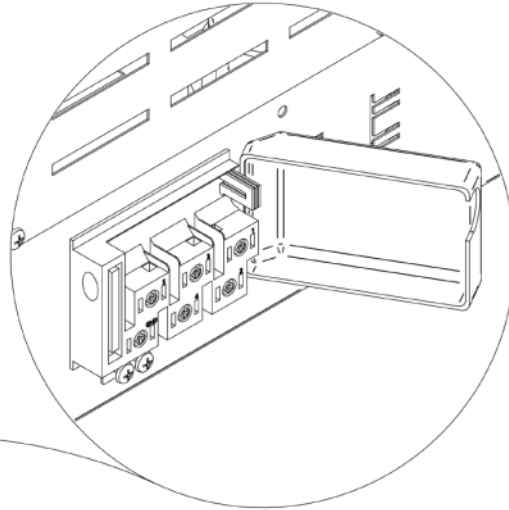
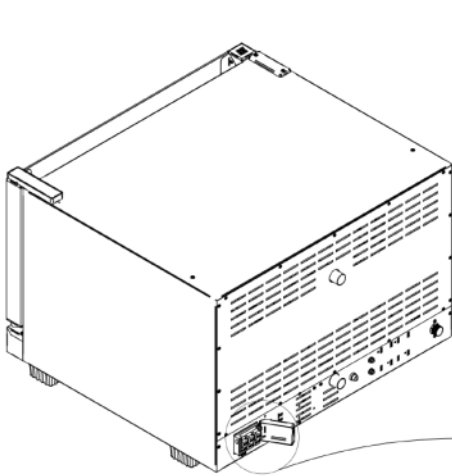

Packaging

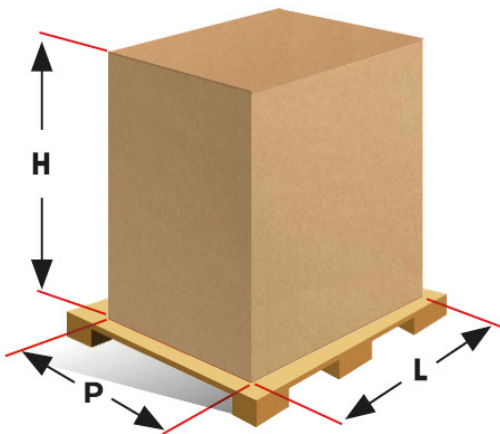

| | |
|---------------|--------------------------|
| Packing size: | 900 L x 900 P x 720 H mm |
| Net weight: | 56 Kg |
| Gross weight: | 66 Kg |