



Gourmet 10T Classic

Gas Supply

CODE: 925907650

Seats	80/160
Trays	10T GN 1/1
Outside dimension	715 L x 800 P x 1110 H mm
Tray distance	65 mm
Power	15 kW - 13.160 Kcal/h (*) - Ele. 0,85 kW
Weight	107 Kg
Max temperature	270° C
Power supply	400 V ~ 3PH + N + PE 400 V ~ 2PH + N + PE 230 V ~ 3PH + PE 230 V ~ 1PH + N + PE 50-60 Hz

Equipment

Led illumination	BakePOINT Multipoint core probe	BakeAIR multi-fan system
Double low emissive glass	High-performance thermal insulation	BakeCLEAN automatic washing system
Premix burner BakeFIRE	Blue LED for chamber cleaning check	Water collection tray
Usable also with GN2/3 and GN1/2 trays	Core probe MultiBakePOINT	Five fan speeds and semi-static cooking
Nine cooking modes	Automatic chimney opening BakeDRY	Program blocking with password
Rounded baking chamber	CE Certificate	Automatic control of dry/steam balance inside the chamber
Steam control in percentage BakeSTEAM	Automatic control of the cooking level and load	Multi-timer function for multiple and mixed cooking
Storage, viewing* and exportation of cooking data (haccp)	Customized programs mode	Manual mode
Preset programs mode	Automatic preheating	Cooling program
Delayed start programming	Delayed cooking programming	Pre-loaded and online cookbook
Automatic detection and errors report	Safety rinse	Openable inner glass for easy cleaning
Fan inversion, speed control and motor brake	Adaptive steam pressure and chamber saturation control	

Options

Heart probe MultiBakePOINT	Fat collection BakeFAT	Left door opening
Data logger for USB connection		

Gourmet 10T Classic

Gas Supply

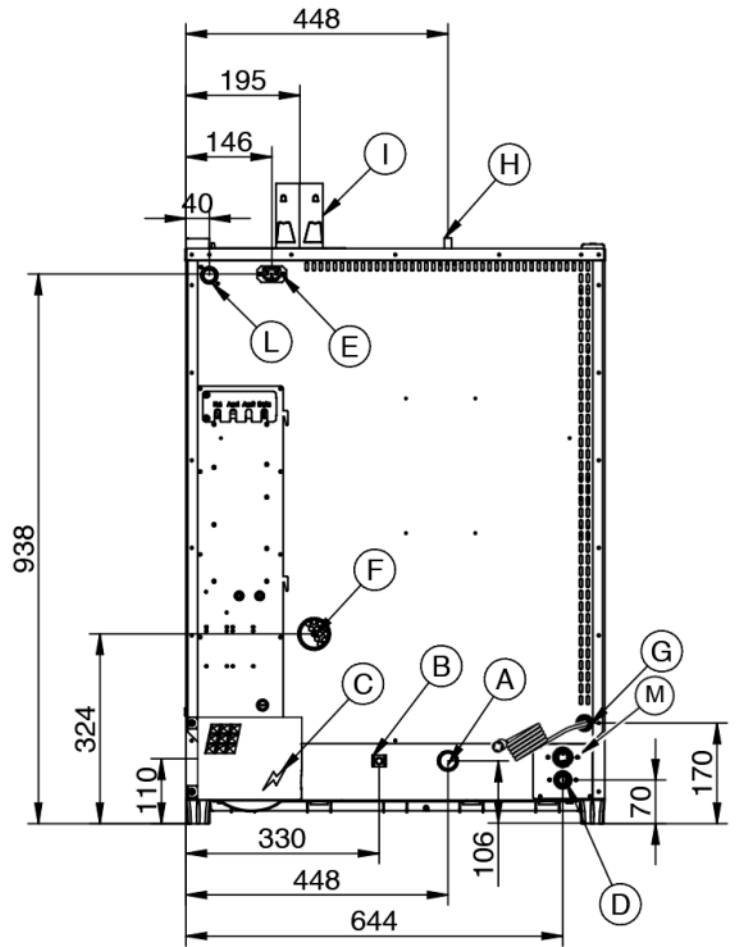
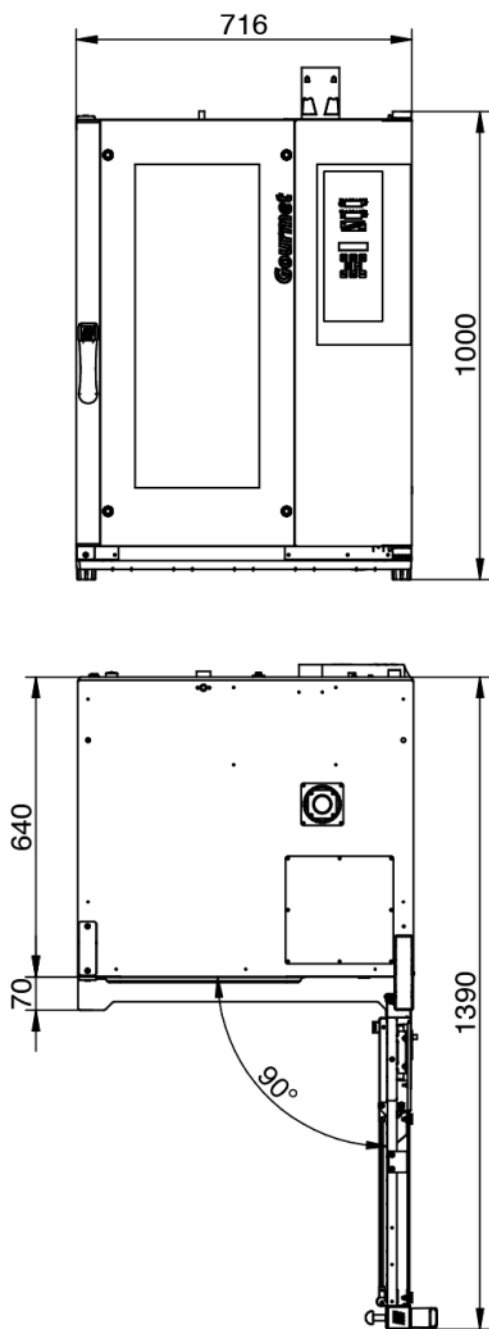

Legend

- A - Drain liquid Ø 30mm
- B - Equipotential terminal comb
- C - Electric supply 0,85 kW
- D - Water inlet 3/4" steam
- E - Extracting hood supply
- F - Steam exhaust Ø 50mm

- G - Inlet for Clean and Care
- H - Depressurizer Ø 12mm
- I - Ø 80mm Combustion chamber fumes exhaust
- L - Gas supply inlet 3/4"
- M - Water inlet 3/4" washing

Gourmet 10T Classic

Gas Supply

Supply and Connections

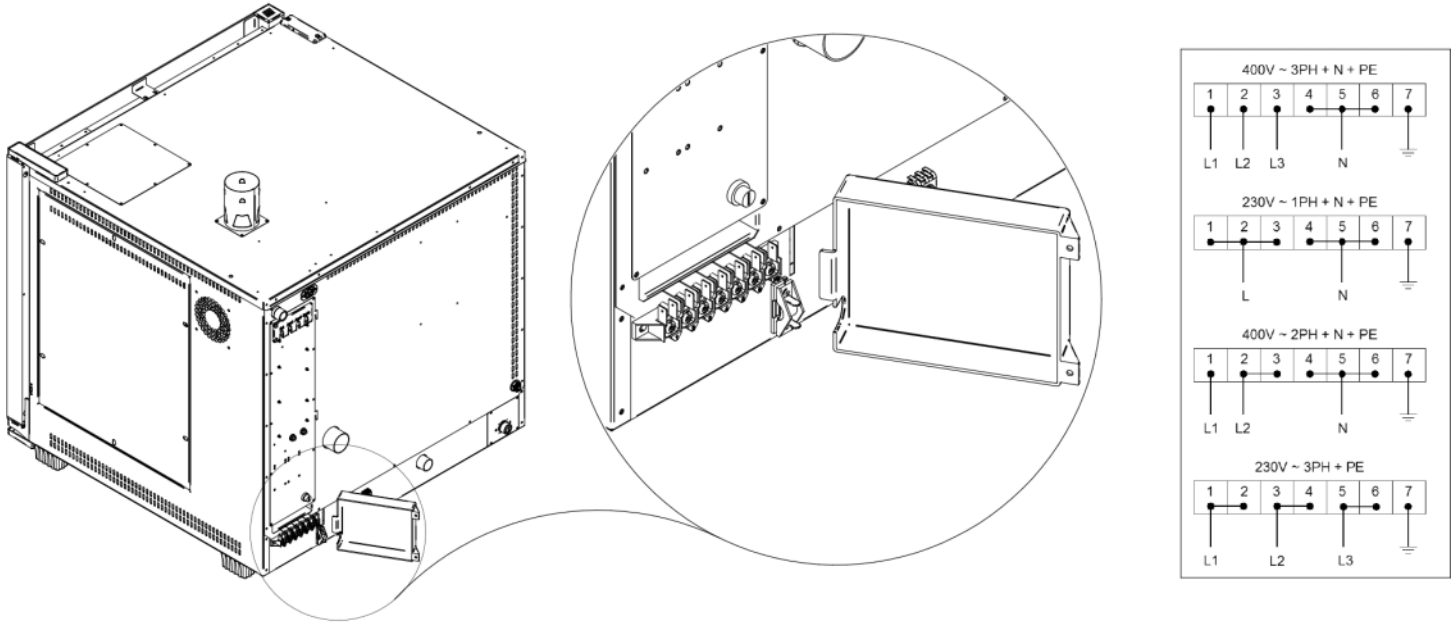

Packaging



Packing size:	790 L x 870 P x 1240 H mm
Net weight:	107 Kg
Gross weight:	116 Kg