



Gourmet 10T GN2/1 Classic

Electrical Supply

CODE: 925913620

Seats	160/240
Trays	20T GN 1/1 - 10T GN 2/1
Outside dimension	920 L x 1010 P x 1150 H mm
Tray distance	80 mm
Power	24 kW
Weight	131 Kg
Max temperature	270° C
Power supply	400 V ~ 3PH + N + PE 400 V ~ 2PH + N + PE 230 V ~ 3PH + PE 230 V ~ 1PH + N + PE 50-60 Hz

Equipment

Led illumination	BakePOINT Multipoint core probe	BakeAIR multi-fan system
Double low emissive glass	High-performance thermal insulation	Blue LED for chamber cleaning check
Water collection tray	Five fan speeds and semi-static cooking	Nine cooking modes
Automatic chimney opening BakeDRY	Program blocking with password	Rounded baking chamber
Modularity	CE Certificate	Automatic control of dry/steam balance inside the chamber
Steam control in percentage BakeSTEAM	Automatic control of the cooking level and load	Multi-timer function for multiple and mixed cooking
Storage, viewing* and exportation of cooking data (haccp)	Customized programs mode	Manual mode
Preset programs mode	Automatic preheating	Cooling program
Delayed start programming	Delayed cooking programming	Pre-loaded and online cookbook
Automatic detection and errors report	Overlap option	Openable inner glass for easy cleaning
Fan inversion, speed control and motor brake	Adaptive steam pressure and chamber saturation control	

Options

Heart probe MultiBakePOINT	BakeCLEAN automatic washing system	Fat collection BakeFAT
Safety rinse	Left door opening	Data logger for USB connection
Extendable height-adjustable feet kit		

Gourmet 10T GN2/1 Classic

Electrical Supply

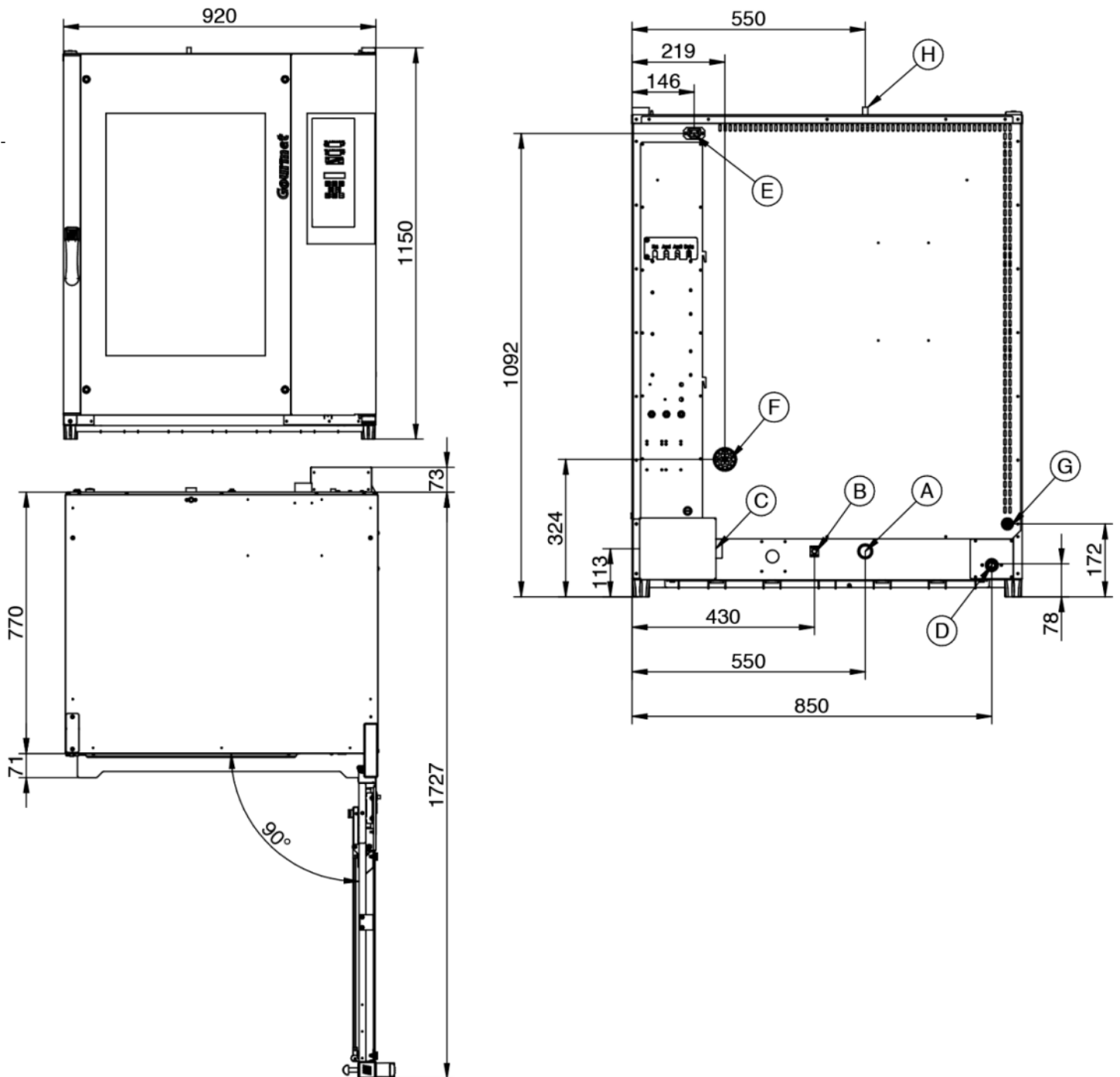

Legend

- A - Drain liquid Ø 30mm
- B - Equipotential terminal comb
- C - Electric supply
- D - Water inlet 3/4"
- E - Extracting hood supply
- F - Steam exhaust Ø 50mm

- G - Inlet for washing kit Ø 8mm
- H - Depressurizer Ø 12mm

Gourmet 10T GN2/1 Classic

Electrical Supply

Supply and Connections

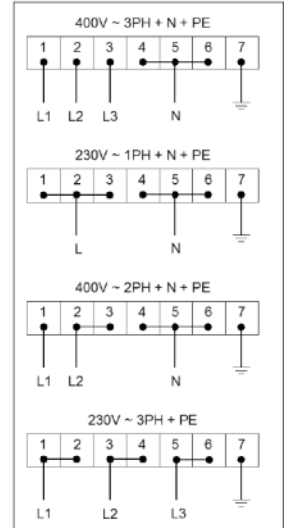
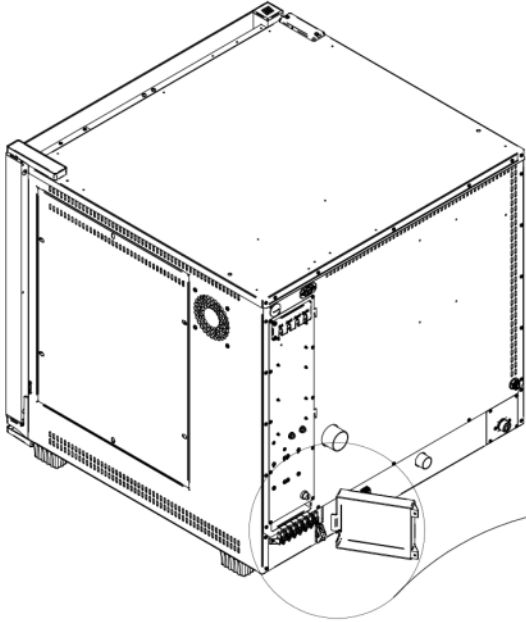

Packaging

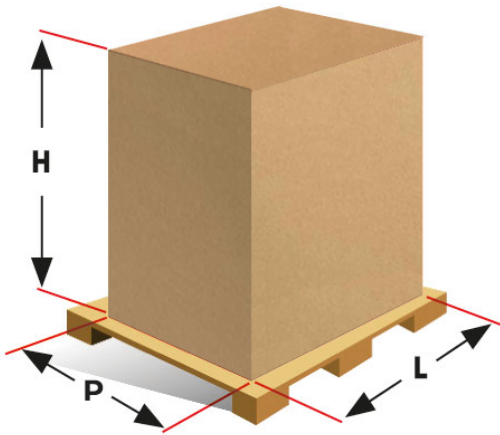

Packing size:	1000 L x 1000 P x 1300 H mm
Net weight:	131 Kg
Gross weight:	141 Kg