



Gourmet 12T-L Master Pro

Gas Supply

CODE: 926013430

Trays	12T GN 1/1
Outside dimension	850 L x 930 P x 1260 H mm
Tray distance	65 mm
Power	16,5 kW - 14.187 Kcal/h (*) - Ele. 1,15 kW
Weight	134 Kg
Max temperature	270° C
Power supply	400 V ~ 3PH + N + PE 400 V ~ 2PH + N + PE 230 V ~ 3PH + PE 230 V ~ 1PH + N + PE 50-60 Hz

Equipment

Led illumination	BakeAIR multi-fan system	Double low emissive glass
High-performance thermal insulation	BakeCLEAN automatic washing system	USB connection
Premix burner BakeFIRE	Blue LED for chamber cleaning check	Water collection tray
Usable also with GN2/3 and GN1/2 trays	Core probe MultiBakePOINT	Set-up for BakeHIN vacuum core probe
Five fan speeds and semi-static cooking	Nine cooking modes	Automatic chimney opening BakeDRY
Program blocking with password	Rounded baking chamber	CE Certificate
Automatic control of dry/steam balance inside the chamber	Steam control in percentage BakeSTEAM	Automatic control of the cooking level and load
Multi-timer function for multiple and mixed cooking	Storage, viewing* and exportation of cooking data (haccp)	Customized programs mode
Manual mode	Preset programs mode	Automatic preheating
Cooling program	Delayed start programming	Delayed cooking programming
Cooking chamber automatic cooling	Pre-loaded and online cookbook	Automatic detection and errors report
Safety rinse	Openable inner glass for easy cleaning	Fan inversion, speed control and motor brake
Adaptive steam pressure and chamber saturation control		

Options

BakeHIN vacuum core probe	Fat collection BakeFAT	Left door opening
---------------------------	------------------------	-------------------

Gourmet 12T-L Master Pro

Gas Supply

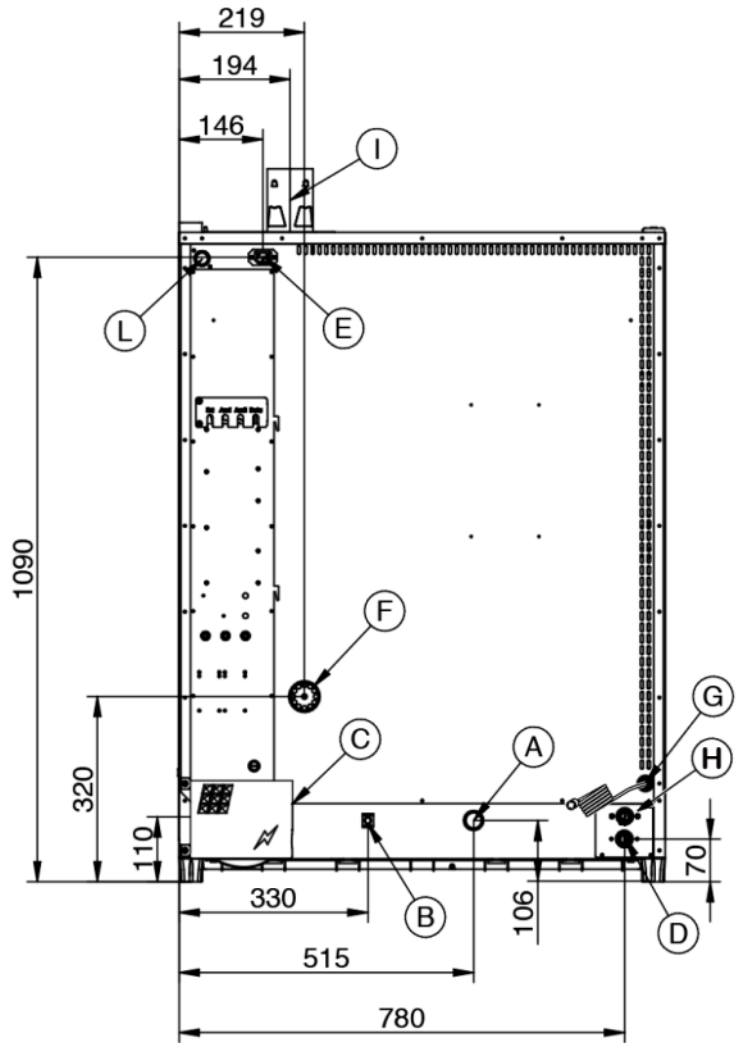
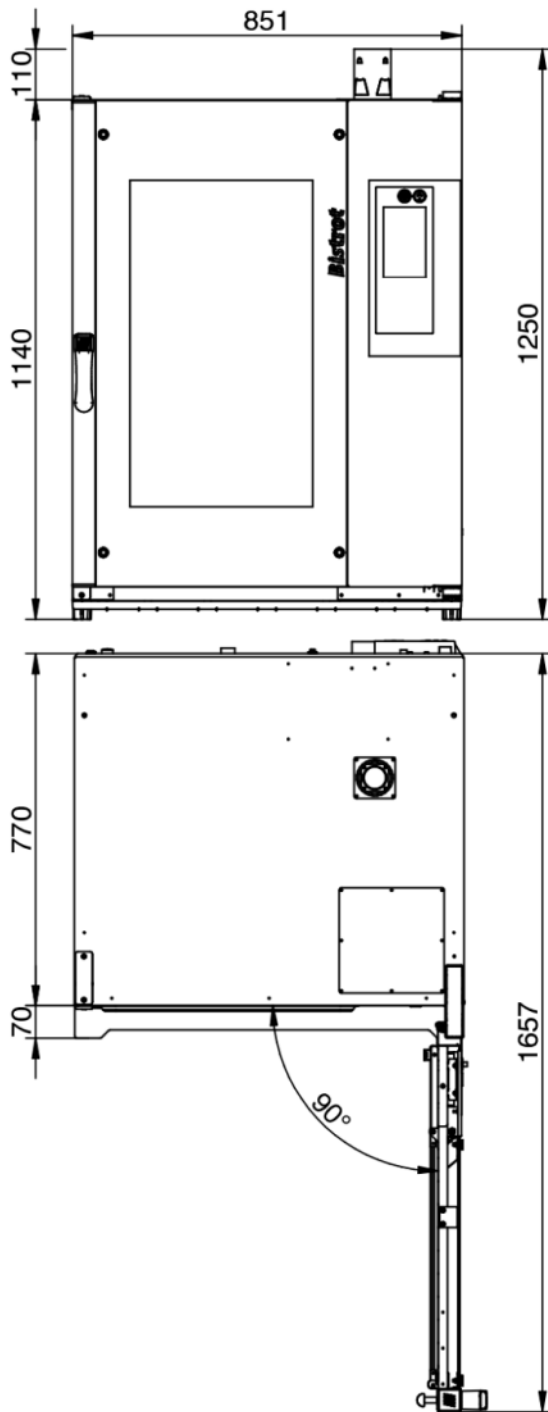

Legend

- A - Drain liquid Ø 30mm
- B - Equipotential terminal comb
- C - Electric supply 1,15 kW
- D - Water inlet 3/4" steam
- E - Extracting hood supply
- F - Steam exhaust Ø 50mm

- G - Inlet Clean and Care
- H - Water inlet 3/4" washing
- I - Ø 80mm Combustion chamber fumes exhaust
- L - Gas supply inlet 3/4"

Gourmet 12T-L Master Pro

Gas Supply

Supply and Connections

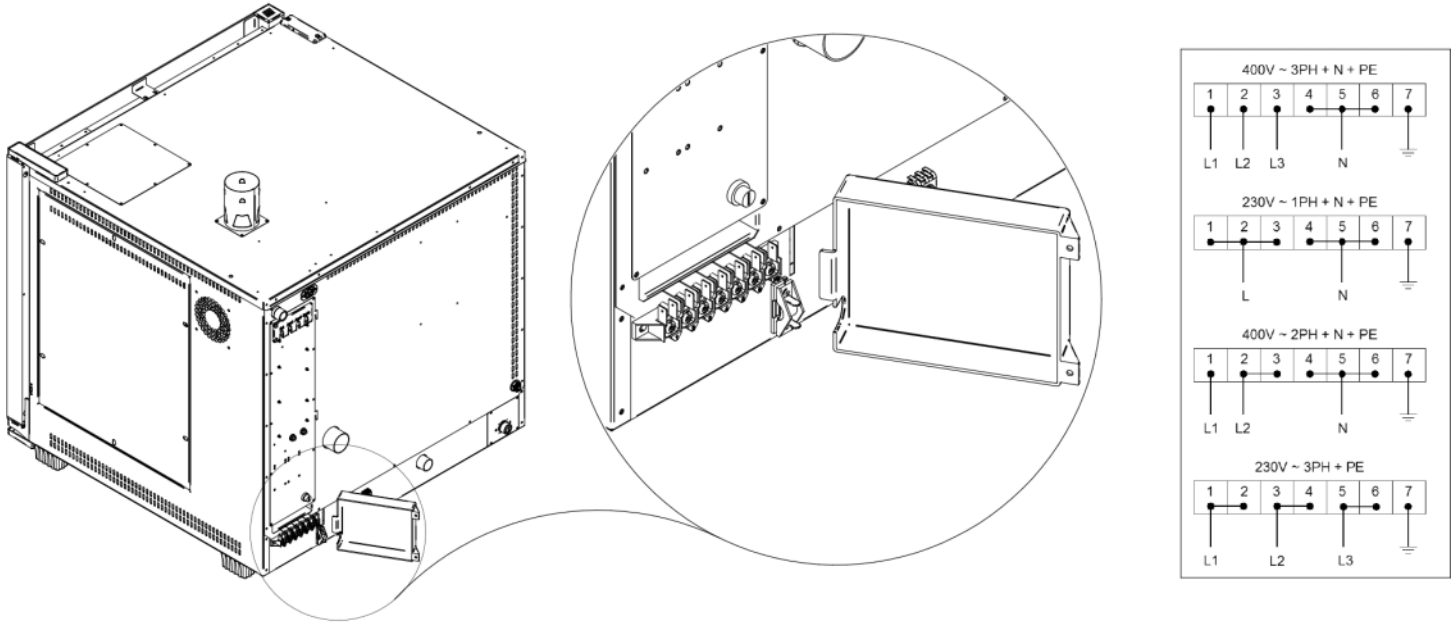

Packaging

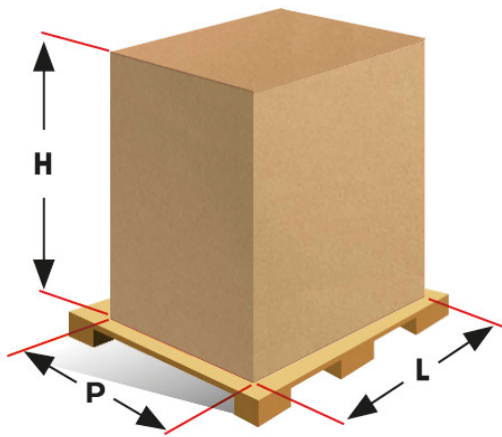

Packing size:	920 L x 1000 P x 1400 H mm
Net weight:	134 Kg
Gross weight:	144 Kg