



Gourmet 6T GN2/1 Master Pro

Electrical Supply

CODE: 926013230

Seats	100/180
Trays	12T GN 1/1 - 6T GN 2/1
Outside dimension	920 L x 920 P x 830 H mm
Tray distance	80 mm
Power	17,5 kW
Weight	95 Kg
Max temperature	270° C
Power supply	400 V ~ 3PH + N + PE 400 V ~ 2PH + N + PE 230 V ~ 3PH + PE 230 V ~ 1PH + N + PE 50-60 Hz

Equipment

Led illumination	BakeAIR multi-fan system	Double low emissive glass
High-performance thermal insulation	USB connection	Blue LED for chamber cleaning check
Water collection tray	Core probe MultiBakePOINT	Set-up for BakeHIN vacuum core probe
Five fan speeds and semi-static cooking	Nine cooking modes	Automatic chimney opening BakeDRY
Program blocking with password	Rounded baking chamber	Modularity
CE Certificate	Automatic control of dry/steam balance inside the chamber	Steam control in percentage BakeSTEAM
Automatic control of the cooking level and load	Multi-timer function for multiple and mixed cooking	Storage, viewing* and exportation of cooking data (haccp)
Customized programs mode	Manual mode	Preset programs mode
Automatic preheating	Cooling program	Delayed start programming
Delayed cooking programming	Cooking chamber automatic cooling	Pre-loaded and online cookbook
Automatic detection and errors report	Overlap option	Openable inner glass for easy cleaning
Fan inversion, speed control and motor brake	Adaptive steam pressure and chamber saturation control	

Options

BakeHIN vacuum core probe	Ethernet connection and wi-fi set-up BakeNET	BakeCLEAN automatic washing system
Fat collection BakeFAT	Safety rinse	Left door opening
Extendable height-adjustable feet kit		

Gourmet 6T GN2/1 Master Pro

Electrical Supply

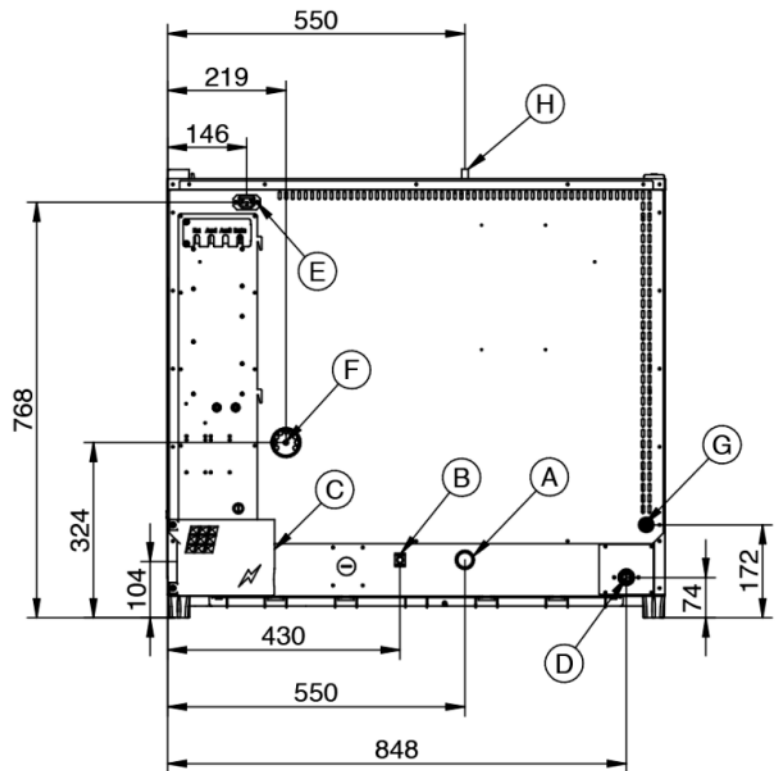
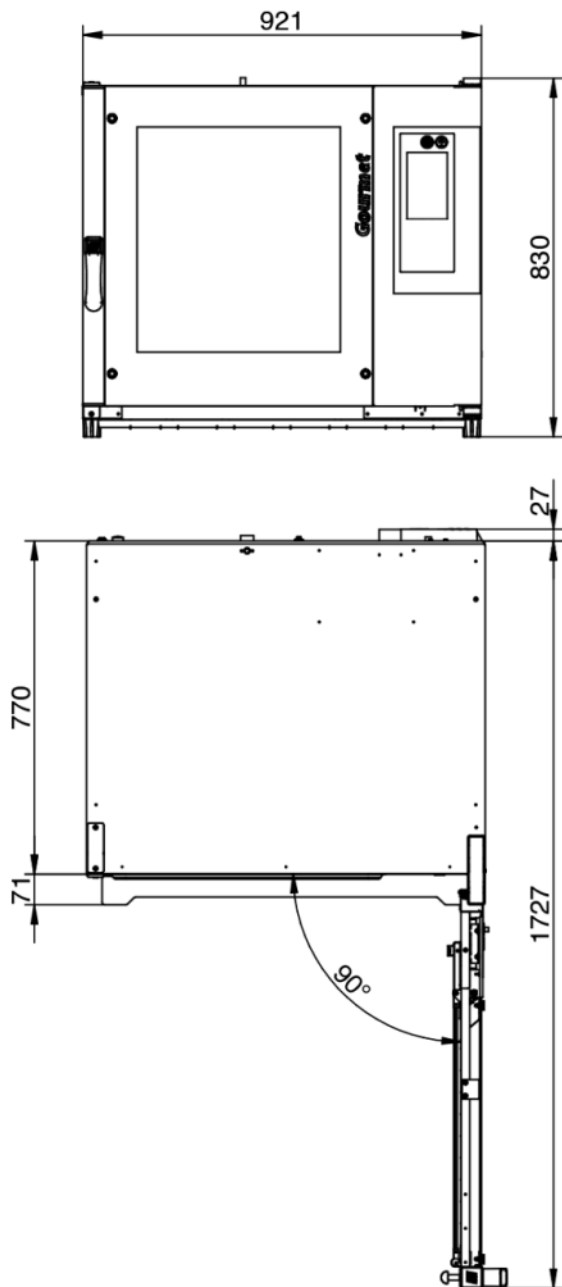

Legend

- A - Drain liquid Ø 30mm
- B - Equipotential terminal comb
- C - Electric supply
- D - Water inlet 3/4"
- E - Extracting hood supply
- F - Steam exhaust Ø 50mm

- G - Inlet for washing kit Ø 8mm
- H - Depressurizer Ø 12mm

Gourmet 6T GN2/1 Master Pro

Electrical Supply

Supply and Connections



Packaging



Packing size:	1000 L x 1000 P x 980 H mm
Net weight:	95 Kg
Gross weight:	105 Kg