



Rack 20T Classic

Electrical Supply

CODE: 925915620

Seats	160/240
Trays	20T GN 1/1
Outside dimension	850 L x 965 P x 1860 H mm
Tray distance	65 mm
Power	32 kW
Weight	177 Kg
Max temperature	270° C
Power supply	400 V ~ 3PH + N + PE 400 V ~ 2PH + N + PE 230 V ~ 3PH + PE 230 V ~ 1PH + N + PE 50-60 Hz

Equipment

Led illumination	BakeAIR multi-fan system	Double low emissive glass
High-performance thermal insulation	BakeCLEAN automatic washing system	Blue LED for chamber cleaning check
Usable also with GN2/3 and GN1/2 trays	Five fan speeds and semi-static cooking	Nine cooking modes
Automatic chimney opening BakeDRY	Program blocking with password	Rounded baking chamber
CE Certificate	Automatic control of dry/steam balance inside the chamber	Steam control in percentage BakeSTEAM
Automatic control of the cooking level and load	Multi-timer function for multiple and mixed cooking	Storage, viewing* and exportation of cooking data (haccp)
Customized programs mode	Manual mode	Preset programs mode
Automatic preheating	Cooling program	Delayed start programming
Delayed cooking programming	Pre-loaded and online cookbook	Automatic detection and errors report
Safety rinse	Openable inner glass for easy cleaning	Fan inversion, speed control and motor brake
Adaptive steam pressure and chamber saturation control		

Options

Heart probe MultiBakePOINT	Data logger for USB connection
----------------------------	--------------------------------

Rack 20T Classic

Electrical Supply

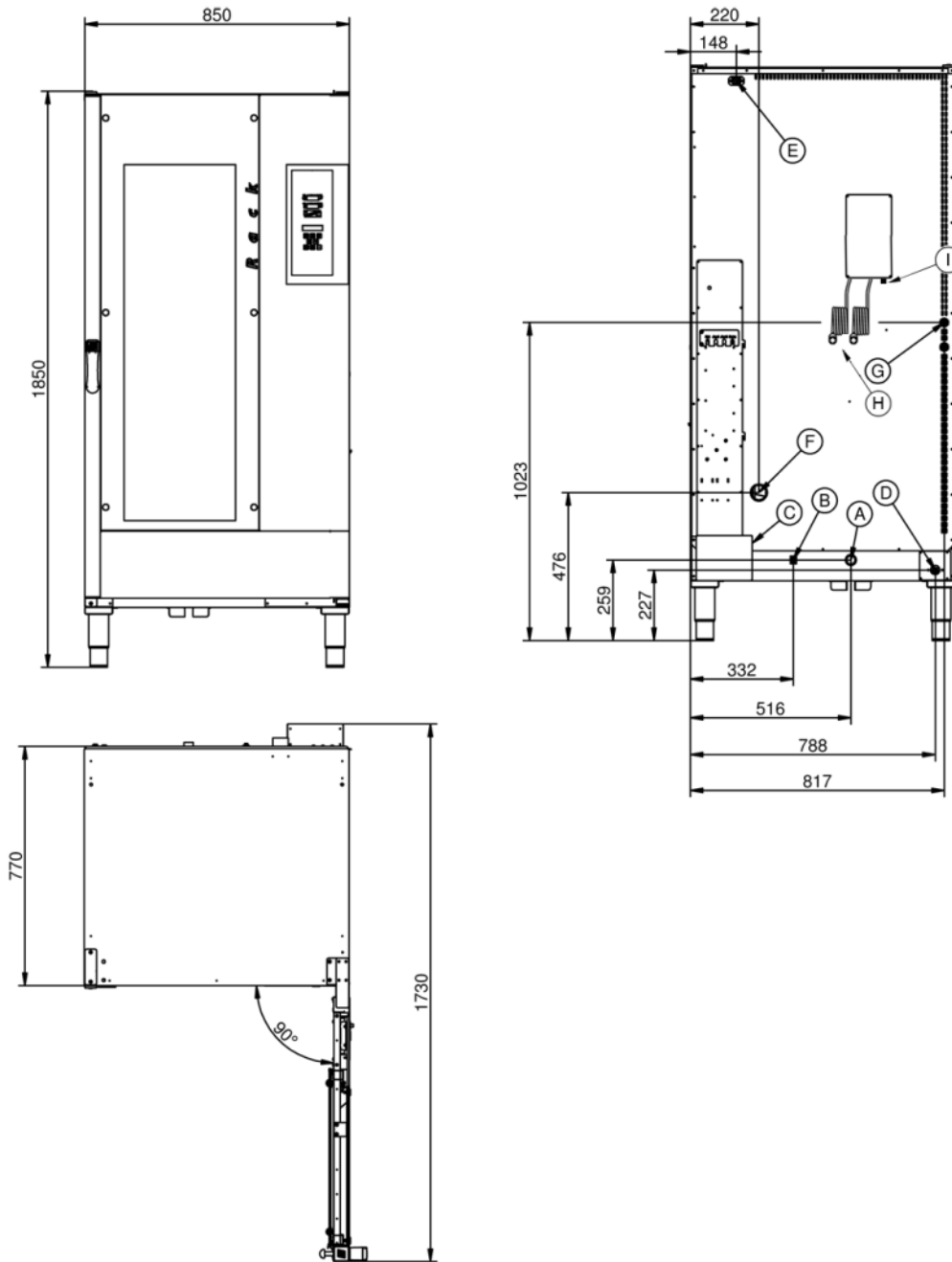

Legend

- | | |
|---|---|
| <ul style="list-style-type: none"> A - Drain liquid Ø 30mm B - Equipotential terminal comb C - Electric supply D - Water inlet 3/4" steam E - Extracting hood supply F - Steam exhaust Ø 50mm | <ul style="list-style-type: none"> G - Inlet for washing kit Ø 8mm H - Inlet for Clean and Care I - Water inlet 3/4" washing |
|---|---|

Rack 20T Classic

Electrical Supply

Supply and Connections

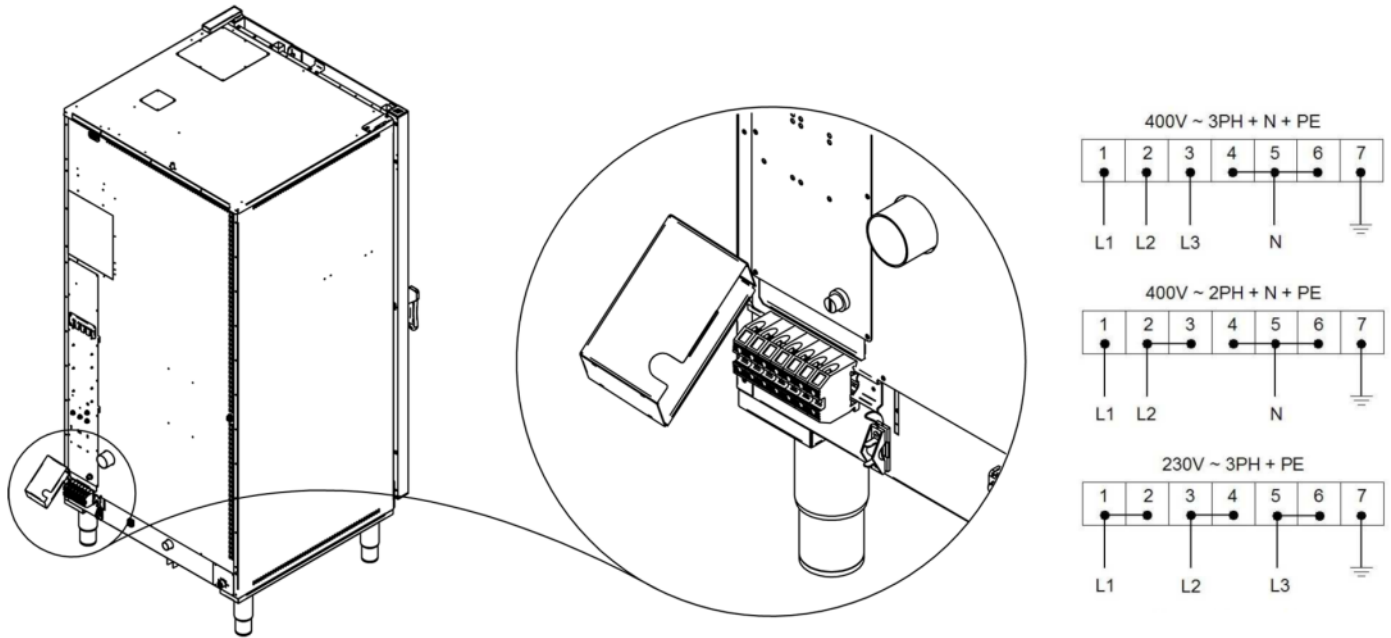

Packaging



Packing size:	950 L x 1040 P x 2090 H mm
Net weight:	177 Kg
Gross weight:	233 Kg