



## Mistral 10T Classic

Electrical Supply

CODE: 926010015

Trays	10T 40x60 46x66 cm
Outside dimension	800 L x 1150 P x 1120 H mm
Tray distance	90 mm
Power	20 kW
Weight	136 Kg
Max temperature	270° C
Power supply	400 V ~ 3PH + N + PE 400 V ~ 2PH + N + PE 230 V ~ 3PH + PE 230 V ~ 1PH + N + PE 50-60 Hz

### Equipment

Led illumination	BakeAIR multi-fan system	Double low emissive glass
High-performance thermal insulation	BakeCLEAN automatic washing system	Blue LED for chamber cleaning check
Five fan speeds and semi-static cooking	Five cooking modes	Automatic chimney opening BakeDRY
Program blocking with password	Rounded baking chamber	Modularity
CE Certificate	Automatic control of dry/steam balance inside the chamber	Steam control in percentage BakeSTEAM
Automatic control of the cooking level and load	Multi-timer function for multiple and mixed cooking	Storage, viewing* and exportation of cooking data (haccp)
Customized programs mode	Manual mode	Preset programs mode
Automatic preheating	Cooling program	Delayed start programming
Delayed cooking programming	Pre-loaded and online cookbook	Automatic detection and errors report
Safety rinse	Overlap option	Openable inner glass for easy cleaning

### Options

Left door opening	Data logger for USB connection
-------------------	--------------------------------

Mistral 10T Classic

Electrical Supply

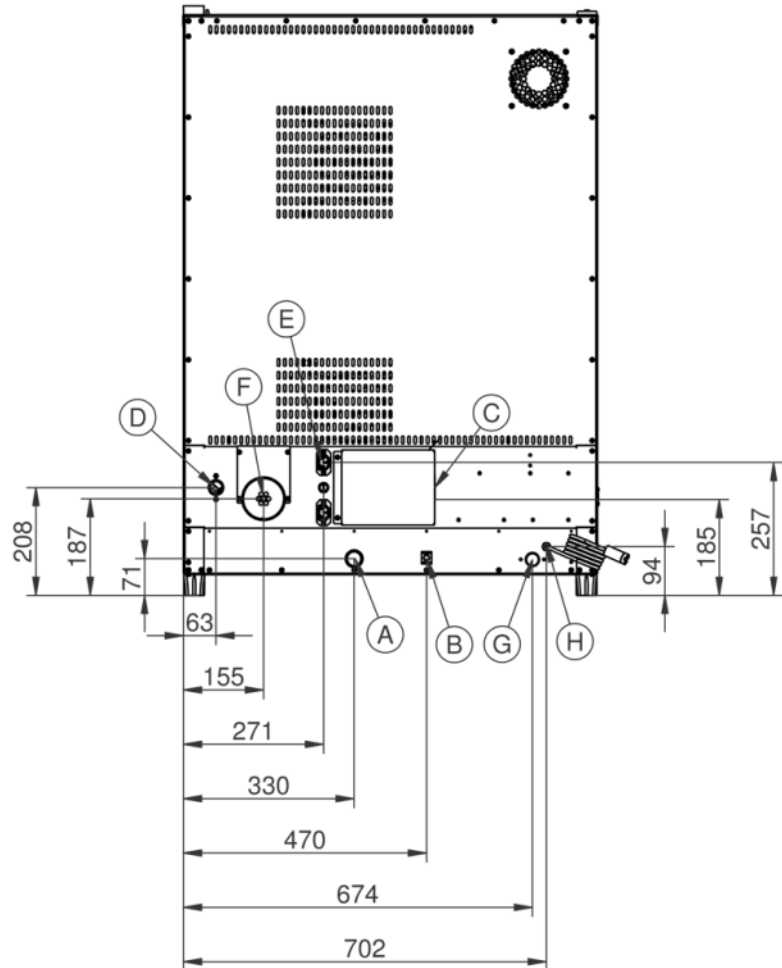
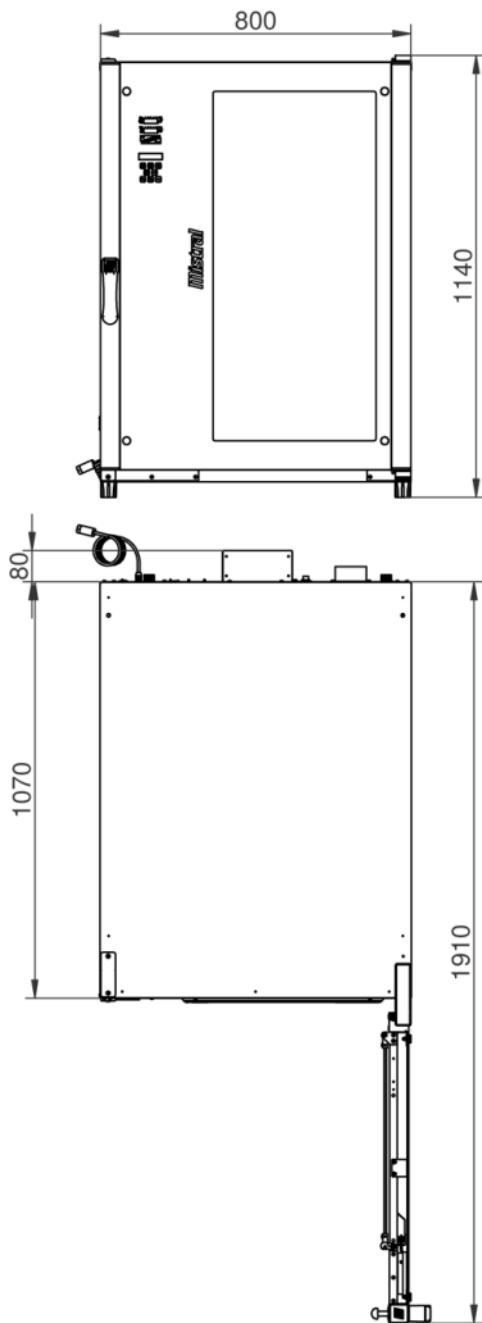

**Legend**

- A - Drain liquid Ø 30mm
- B - Equipotential terminal comb
- C - Electric supply
- D - Water inlet 3/4"
- E - Extracting hood supply
- F - Steam exhaust Ø 80mm

- G - Inlet for washing kit 3/4"
- H - Wash suction pipe for detergent

Mistral 10T Classic

Electrical Supply

Supply and Connections

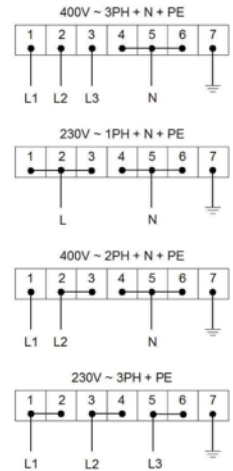
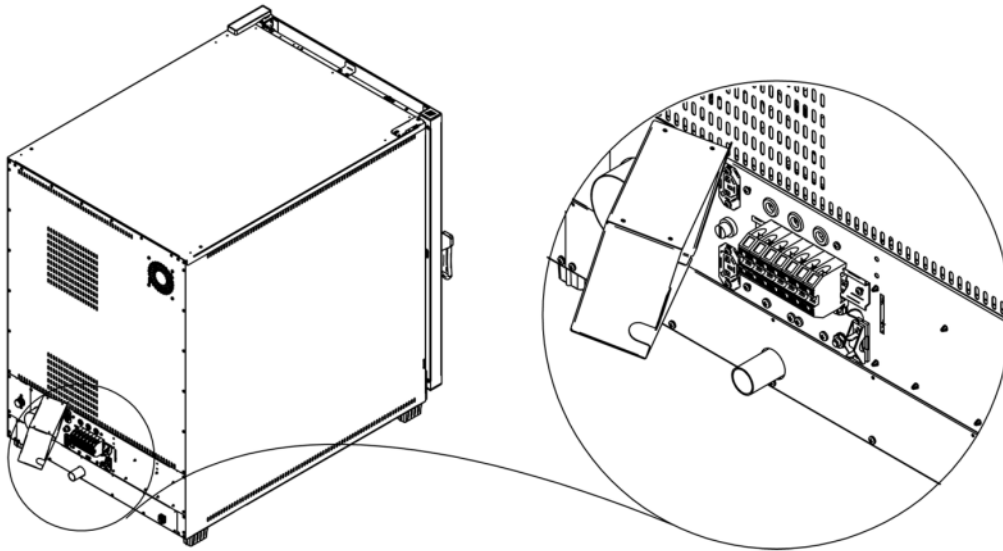

Packaging

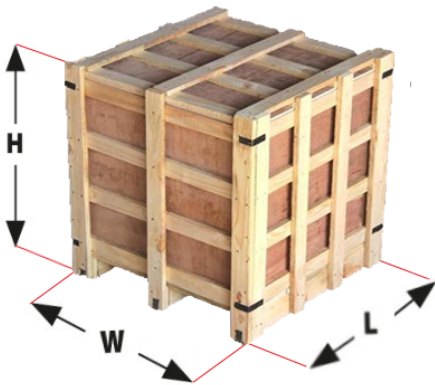

Packing size:	900 L x 1330 P x 1320 H mm
Net weight:	136 Kg
Gross weight:	189 Kg