



Mistral 5T Manual

Electrical Supply

CODE: 926005030

Trays	5T 40x60 46x66 cm
Outside dimension	800 L x 1150 P x 670 H mm
Tray distance	90 mm
Power	9 kW
Weight	85 Kg
Max temperature	270° C
Power supply	400 V ~ 3PH + N + PE 400 V ~ 2PH + N + PE 230 V ~ 3PH + PE 230 V ~ 1PH + N + PE 50-60 Hz

Equipment

Led illumination	BakeAIR multi-fan system	Double low emissive glass
High-performance thermal insulation	Rounded baking chamber	CE Certificate
Manual steam injection	Manual mode	

Options

Left door opening

Mistral 5T Manual

Electrical Supply

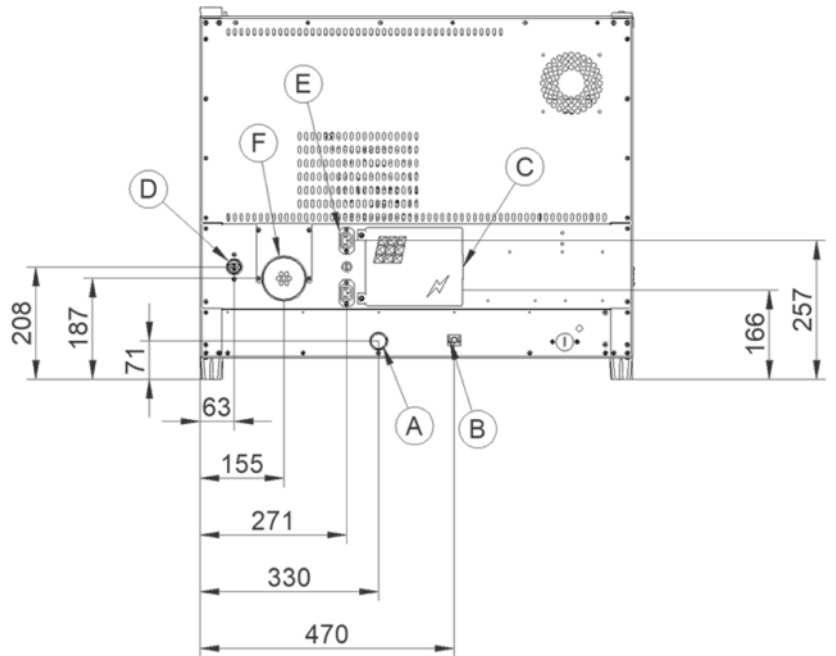
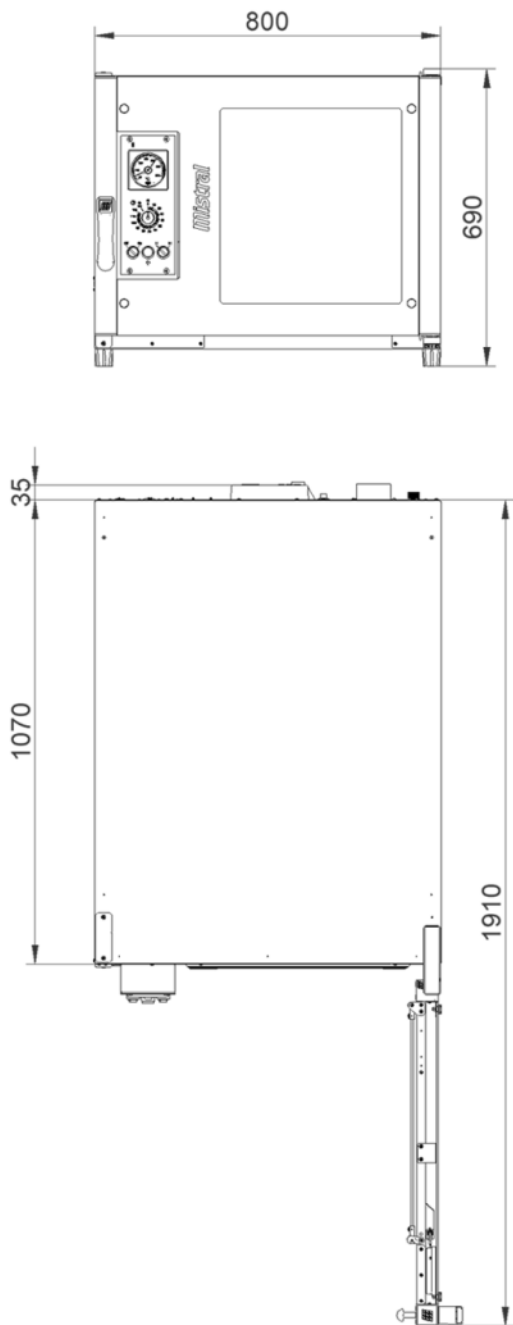

Legend

- A - Drain liquid Ø 30mm
- B - Equipotential terminal comb
- C - Electric supply
- D - Water inlet 3/4"
- F - Steam exhaust Ø 80mm

Mistral 5T Manual

Electrical Supply

Supply and Connections



Packaging



Packing size:	900 L x 1330 P x 870 H mm
Net weight:	85 Kg
Gross weight:	125 Kg