



Rotorbake T11 18T Classic

Gas Supply

CODE: 926018350

Trays	18T 80x80 (11.5m ²) 2x46x66 (10.9m ²) 66x92 (10.9m ²) 80x100cm (14.4m ²)
Outside dimension	1550 L x 2244 P x 2504 H mm
Tray distance	93 mm
Power	70 kW - 60.000 Kcal/h - Ele. 2 kW
Weight	1150 Kg
Max temperature	270° C
Power supply	400 V ~ 3PH + N + PE 230 V ~ 3PH + PE 230 V ~ 1PH + N + PE 50-60 Hz

Equipment

BakeAIR multi-fan system	Double low emissive glass	High-performance thermal insulation
Five fan speeds and semi-static cooking	Five cooking modes	Automatic chimney opening BakeDRY
Program blocking with password	Combustion chamber covered by 7-year warranty	Heat exchanger inside the cooking chamber
CE Certificate	Automatic control of dry/steam balance inside the chamber	Steam control in percentage BakeSTEAM
Automatic control of the cooking level and load	Double steamer RotorBake	Multi-timer function for multiple and mixed cooking
Storage, viewing* and exportation of cooking data (haccp)	Customized programs mode	Manual mode
Preset programs mode	ETL / NSF certification	Automatic preheating
Cooling program	Delayed start programming	Delayed cooking programming
Pre-loaded and online cookbook	Automatic detection and errors report	

Options

S/S external paneling	Double-closing door and double gasket	Rotating platform
Rack automatic lift for Rotorbake	Left door opening	Data logger for USB connection

Rotorbake T11 18T Classic

Gas Supply

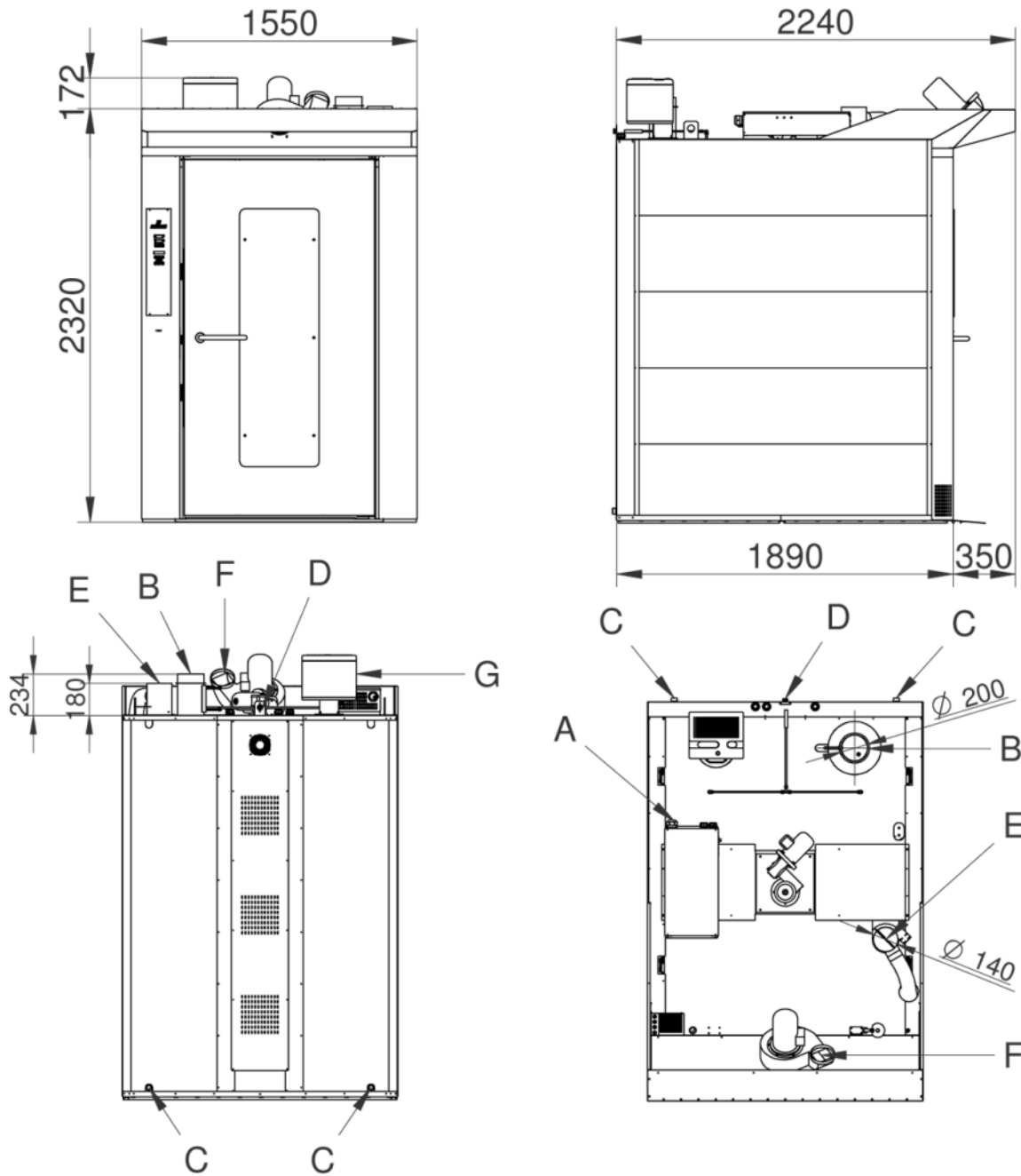

Legend

- A - Electric supply 2 kW - (Pg36)
- B - $\varnothing 200$ mm Combustion chamber fumes exhaust
- C - Water discharge 1"
- D - Water inlet 3/4"
- E - Chamber steam discharge $\varnothing 140$
- F - Extractor hood discharge

G - Burner

Rotorbake T11 18T Classic

Gas Supply

Supply and Connections

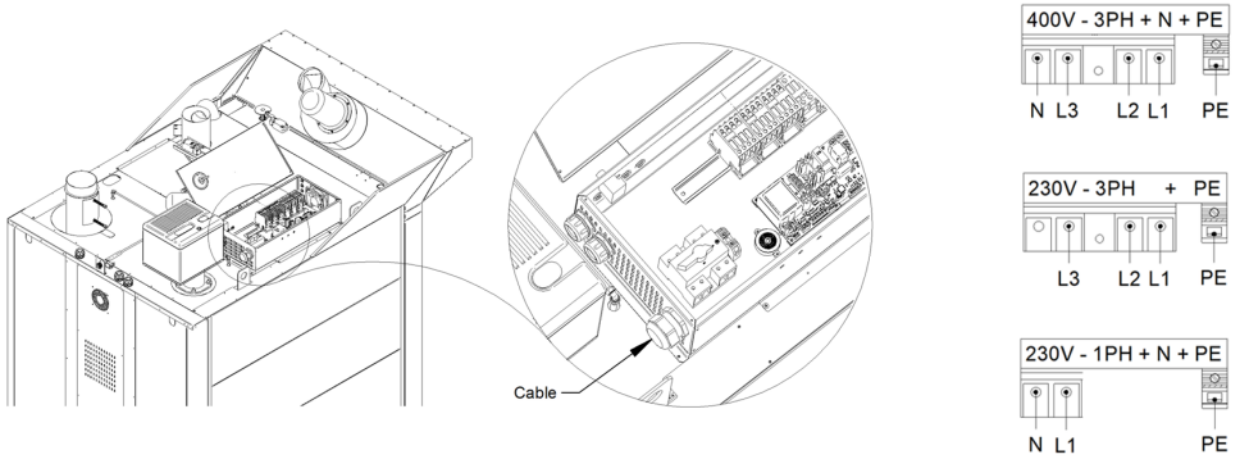

Packaging



Packing size:	1660 L x 2250 P x 2550 H mm
Net weight:	1150 Kg
Gross weight:	1250Kg