



## Rotorbake E16 18T Master Pro

Electrical Supply

CODE: 926018630

|                   |   |
|-------------------|---|
| Trays             | 18T 80x120 cm (17.2m <sup>2</sup> )                                 |
| Outside dimension | 1950 L x 2674 P x 2504 H mm   |
| Tray distance     | 93 mm   |
| Power             | 80 kW   |
| Weight            | 1200 Kg   |
| Max temperature   | 270° C  |
| Power supply      | 400 V ~ 3PH + N + PE 230 V ~ 3PH + PE 230 V ~ 1PH + N + PE 50-60 Hz |

### Equipment

|   |   |   |
|---|---|---|
| BakeAIR multi-fan system                                  | Double low emissive glass                                 | High-performance thermal insulation             |
| USB connection  | Five fan speeds and semi-static cooking                   | Five cooking modes                              |
| Automatic chimney opening BakeDRY                         | Program blocking with password                            | CE Certificate                                  |
| Automatic control of dry/steam balance inside the chamber | Steam control in percentage BakeSTEAM                     | Automatic control of the cooking level and load |
| Double steamer RotorBake                                  | Multi-timer function for multiple and mixed cooking       | Time-programmable steam injection               |
| Manual steam injection                                    | Storage, viewing* and exportation of cooking data (haccp) | Customized programs mode                        |
| Manual mode   | Preset programs mode                                      | Automatic preheating                            |
| Cooling program   | Delayed start programming                                 | Delayed cooking programming                     |
| Cooking chamber automatic cooling                         | Pre-loaded and online cookbook                            | Automatic detection and errors report           |

### Options

|  |                               |                                       |
|--|-------------------------------|---------------------------------------|
| Ethernet connection and wi-fi set-up BakeNET | S/S external paneling         | Double-closing door and double gasket |
| Rotating platform                            | Double-rack rotating platform | Rack automatic lift for Rotorbake     |
| Left door opening                            |                               |                                       |

Rotorbake E16 18T Master Pro

Electrical Supply

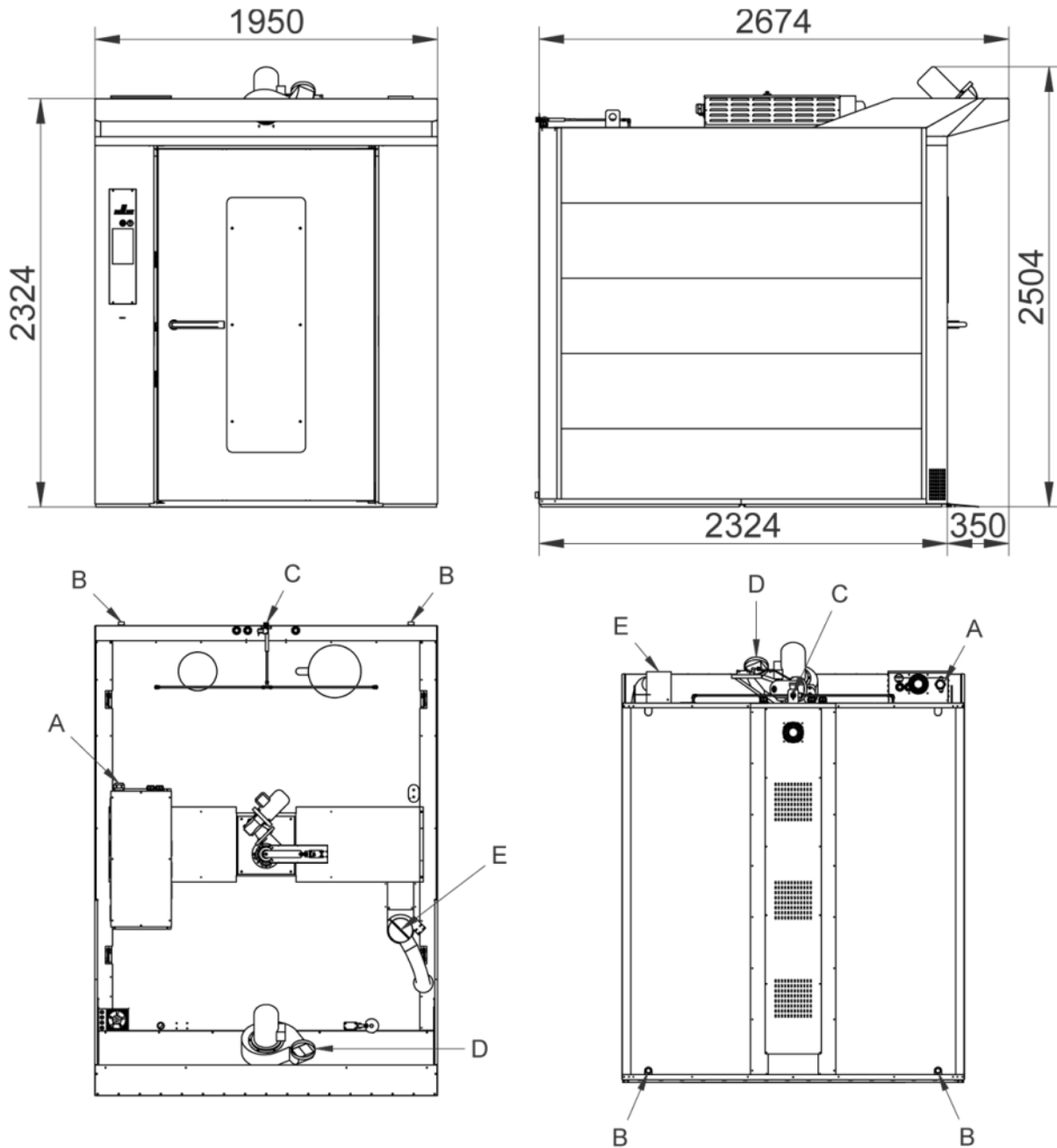

**Legend**

- A - Power supply inlet
- B - Water discharge 1"
- C - Water inlet 3/4"
- D - Extractor hood discharge
- E - Chamber steam discharge Ø 140

**Rotorbake E16 18T Master Pro**

Electrical Supply

**Supply and Connections**

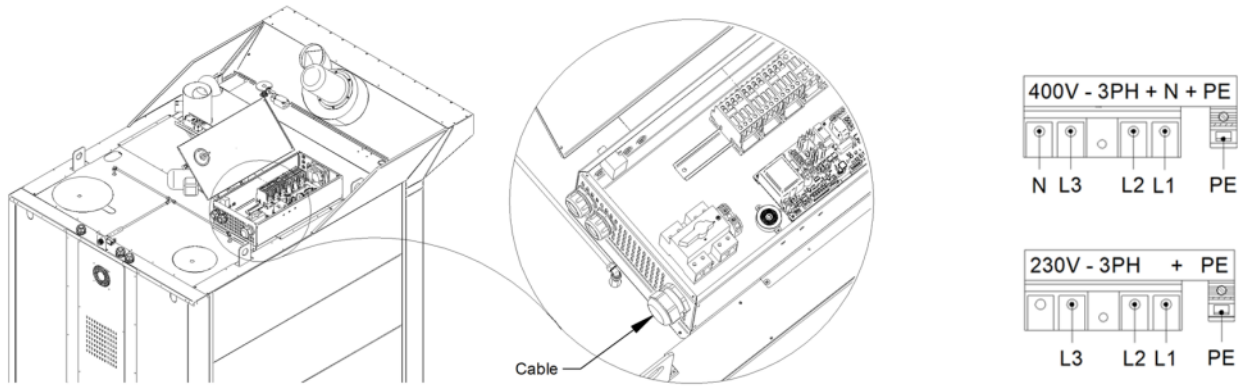

**Packaging**



|               |                             |
|---------------|-----------------------------|
| Packing size: | 2030 L x 2670 P x 2550 H mm |
| Net weight:   | 1200 Kg                     |
| Gross weight: | 1390 Kg                     |