



Rotorbake T16 18T Manual

Gas Supply

CODE: 926018670

Trays	18T 80x120 cm (17.2m ²)
Outside dimension	1950 L x 2674 P x 2504 H mm
Tray distance	93 mm
Power	93 kW - 80.000 Kcal/h - Ele. 2 kW
Weight	1300 Kg
Max temperature	270° C
Power supply	400 V ~ 3PH + N + PE 400 V ~ 2PH + N + PE 230 V ~ 3PH + PE 230 V ~ 1PH + N + PE 50-60 Hz

Equipment

BakeAIR multi-fan system	Double low emissive glass	High-performance thermal insulation
Combustion chamber covered by 7-year warranty	Heat exchanger inside the cooking chamber	CE Certificate
Double steamer RotorBake	Time-programmable steam injection	Manual steam injection
Manual mode		

Options

S/S external paneling	Double-closing door and double gasket	Rotating platform
Double-rack rotating platform	Rack automatic lift for Rotorbake	Left door opening

Rotorbake T16 18T Manual

Gas Supply

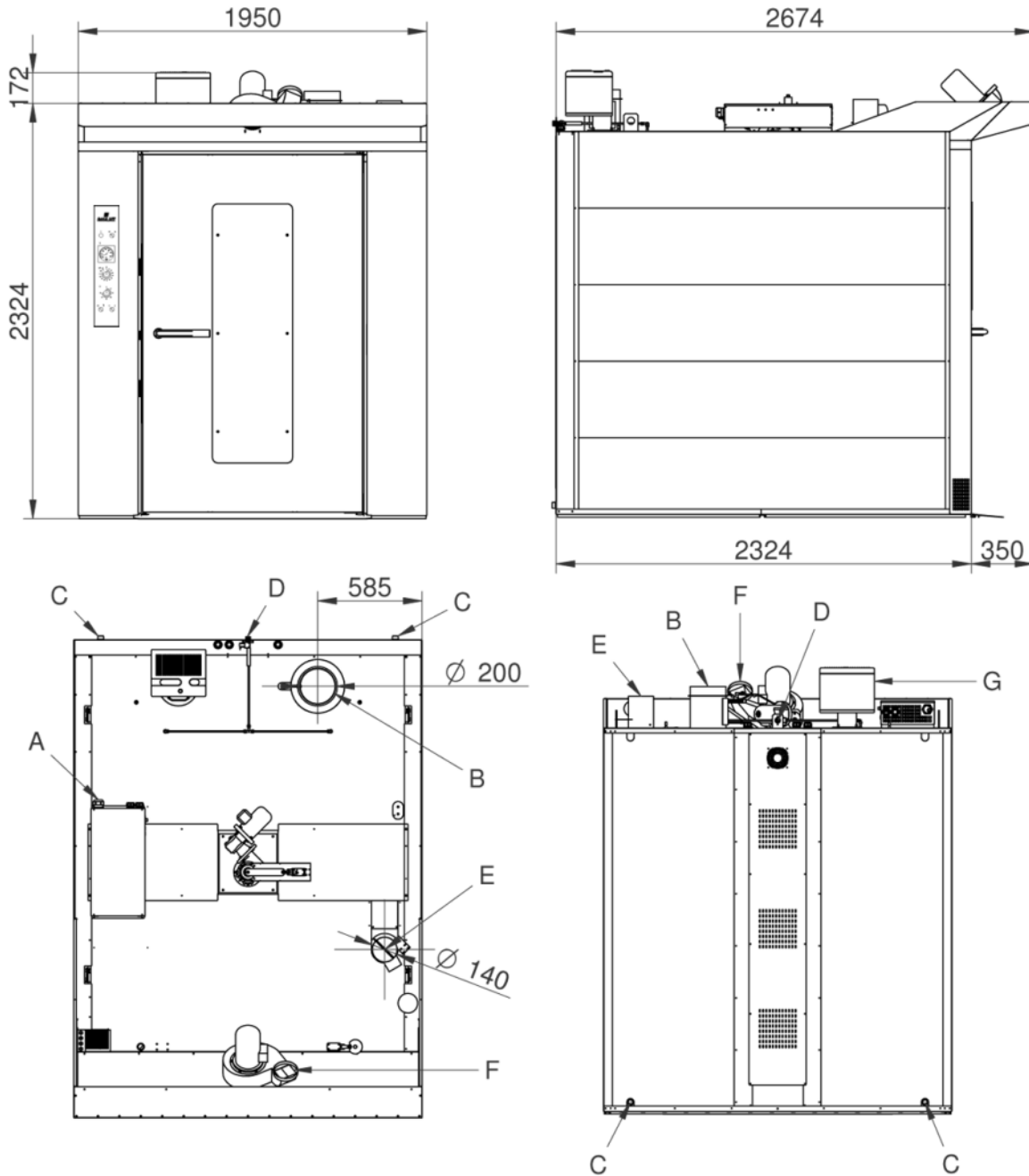

Legend

- A - Electric supply 2 kW - (Pg36)
- B - Ø 200mm Combustion chamber fumes exhaust
- C - Water discharge 1"
- D - Water inlet 3/4"
- E - Chamber steam discharge Ø 140
- F - Extractor hood discharge

G - Burner

Rotorbake T16 18T Manual

Gas Supply

Supply and Connections



Packaging



Packing size:	2030 L x 2670 P x 2550 H mm
Net weight:	1300 Kg
Gross weight:	1490 Kg