



Rotorbake E2 10T 50×70 Master Pro

Electrical Supply

CODE: 926009240

Trays	10T 50x70 cm (3.5m ²)
Outside dimension	1150 L x 1200 P x 1310 H mm
Tray distance	82 mm
Power	16 kW
Weight	265 Kg
Max temperature	270° C
Power supply	400 V ~ 3PH + N + PE 400 V ~ 2PH + N + PE 230 V ~ 3PH + PE 230 V ~ 1PH + N + PE 50-60 Hz

Equipment

BakeAIR multi-fan system	Double low emissive glass	High-performance thermal insulation
USB connection	Five fan speeds and semi-static cooking	Five cooking modes
Automatic chimney opening BakeDRY	Program blocking with password	CE Certificate
Automatic control of dry/steam balance inside the chamber	Steam control in percentage BakeSTEAM	Automatic control of the cooking level and load
Multi-timer function for multiple and mixed cooking	Time-programmable steam injection	Manual steam injection
Storage, viewing* and exportation of cooking data (haccp)	Customized programs mode	Manual mode
Preset programs mode	Automatic preheating	Cooling program
Delayed start programming	Delayed cooking programming	Cooking chamber automatic cooling
Pre-loaded and online cookbook	Automatic detection and errors report	Openable inner glass for easy cleaning

Options

Ethernet connection and wi-fi set-up BakeNET

Rotorbake E2 10T 50×70 Master Pro

Electrical Supply

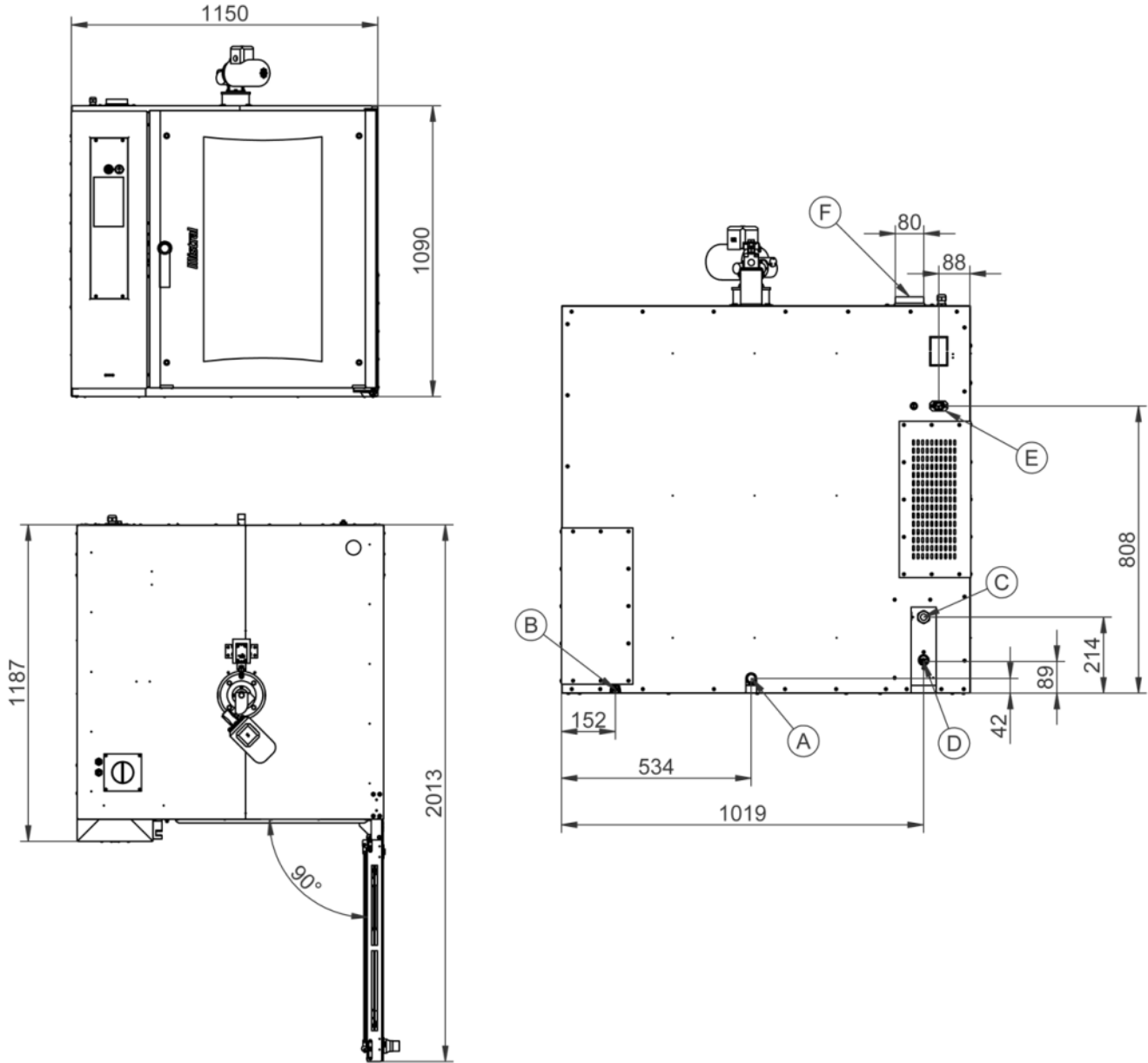

Legend

- A - Drain liquid Ø 30mm
- B - Equipotential terminal comb
- C - Electric supply
- D - Water inlet 3/4"
- E - Extracting hood supply
- F - Steam exhaust Ø 80mm

Rotorbake E2 10T 50x70 Master Pro

Electrical Supply

Supply and Connections

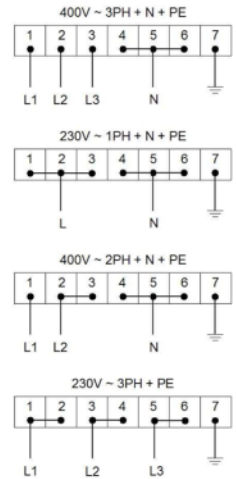
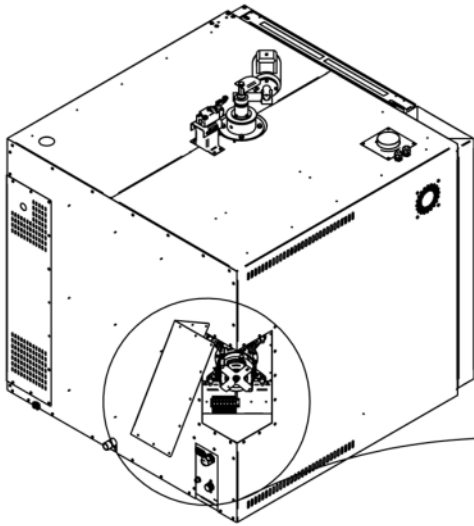

Packaging

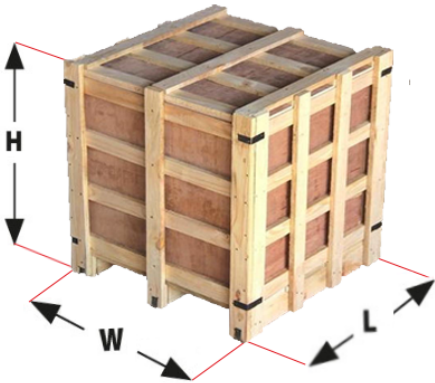

Packing size:	1240 L x 1400 P x 1520 H mm
Net weight:	265 Kg
Gross weight:	305 Kg