



## Rotorbake T5 15T Manual

Gas Supply

CODE: 825818890

Trays	15T 40x60cm (3.6m <sup>2</sup> )   40x80cm (4.8m <sup>2</sup> )   46x66cm (4.55 m <sup>2</sup> )   50x70cm (5.25 m <sup>2</sup> )   60x65cm (5.85 m <sup>2</sup> )
Outside dimension	1150 L x 1730 P x 2320 H mm
Tray distance	93 mm
Power	34.8 kW - 30.000 Kcal/h - Ele. 1,6 kW
Weight	715 Kg
Max temperature	270° C
Power supply	400 V ~ 3PH + N + PE 400 V ~ 2PH + N + PE 230 V ~ 3PH + PE 230 V ~ 1PH + N + PE 50-60 Hz

### Equipment

BakeAIR multi-fan system	Double low emissive glass	High-performance thermal insulation
Combustion chamber covered by 7-year warranty	Heat exchanger inside the cooking chamber	CE Certificate
Double steamer RotorBake	Time-programmable steam injection	Manual steam injection
Manual mode		

### Options

S/S external paneling	Double-closing door and double gasket	Rotating platform
Rack automatic lift for Rotorbake	Left door opening	

Rotorbake T5 15T Manual

Gas Supply

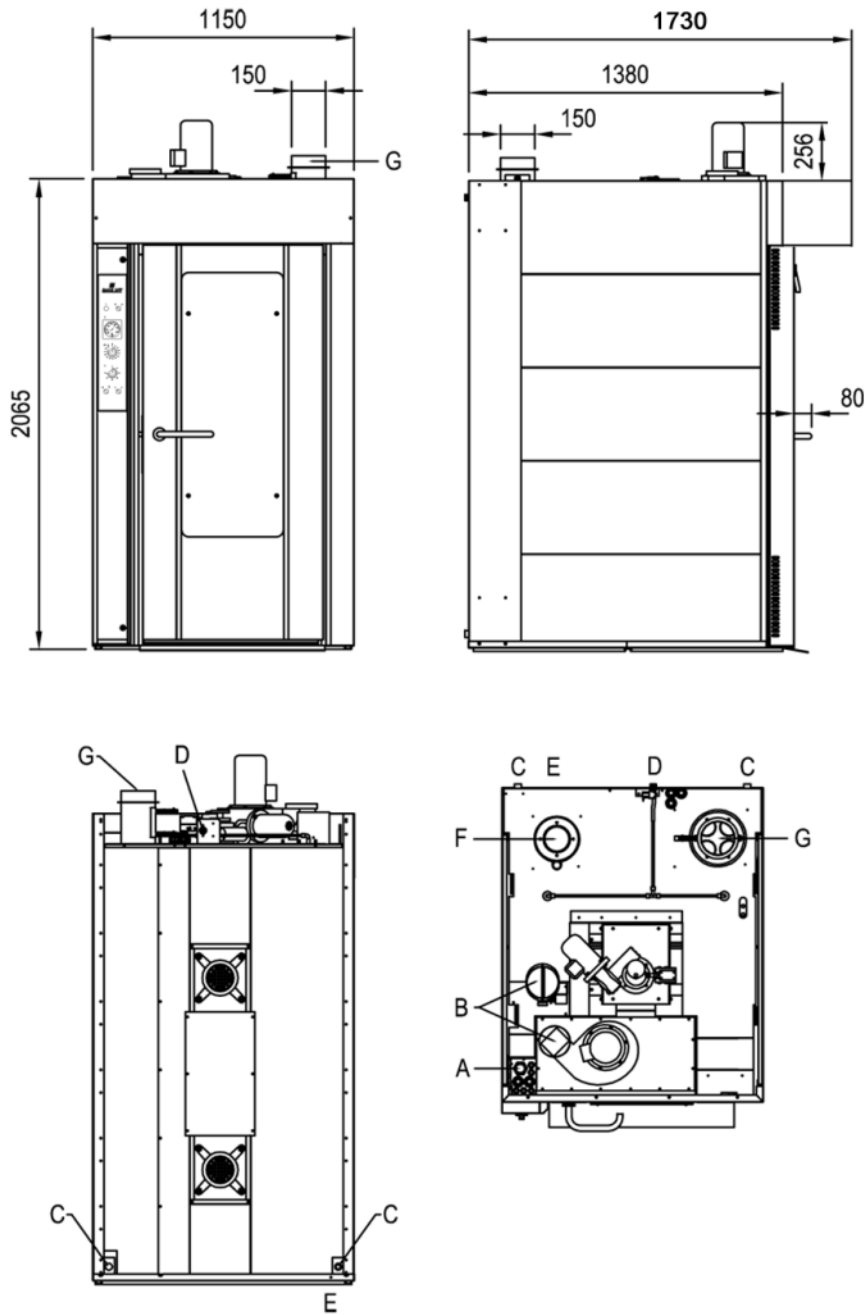

**Legend**

- A - Electric supply 1,6 kW
- B - Steam exhaust Ø 140
- C - Drain liquid 1"
- D - Water inlet 3/4"
- E - Equipotential terminal comb
- F - Burner

G - Ø 150mm Combustion chamber fumes exhaust

Rotorbake T5 15T Manual

Gas Supply

Supply and Connections

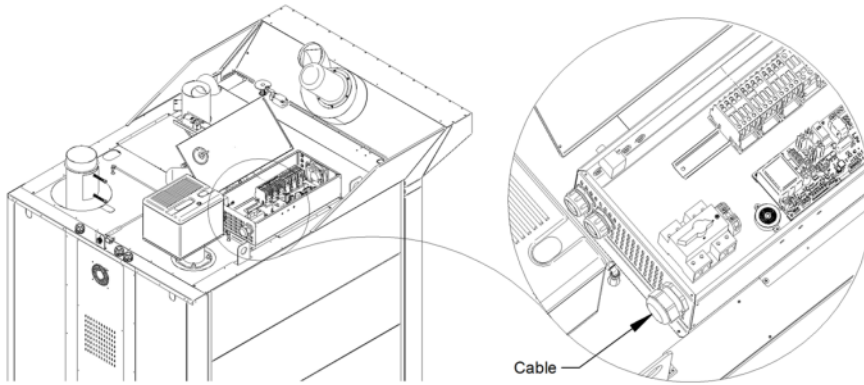

Packaging



Packing size:	1270 L x 1650 P x 2300 H mm
Net weight:	715 Kg
Gross weight:	785 Kg