



Rotorbake E8 18T Manual

Electrical Supply

CODE: 926018220

Trays	18T 60x80 cm (8.6m ²)
Outside dimension	1300 L x 1939 P x 2504 H mm
Tray distance	93 mm
Power	47 kW
Weight	800 Kg
Max temperature	270° C
Power supply	400 V ~ 3PH + N + PE 400 V ~ 2PH + N + PE 230 V ~ 3PH + PE 230 V ~ 1PH + N + PE 50-60 Hz

Equipment

BakeAIR multi-fan system	Double low emissive glass	High-performance thermal insulation
CE Certificate	Double steamer RotorBake	Time-programmable steam injection
Manual steam injection	Manual mode	

Options

S/S external paneling	Double-closing door and double gasket	Rotating platform
Rack automatic lift for Rotorbake	Left door opening	

Rotorbake E8 18T Manual

Electrical Supply

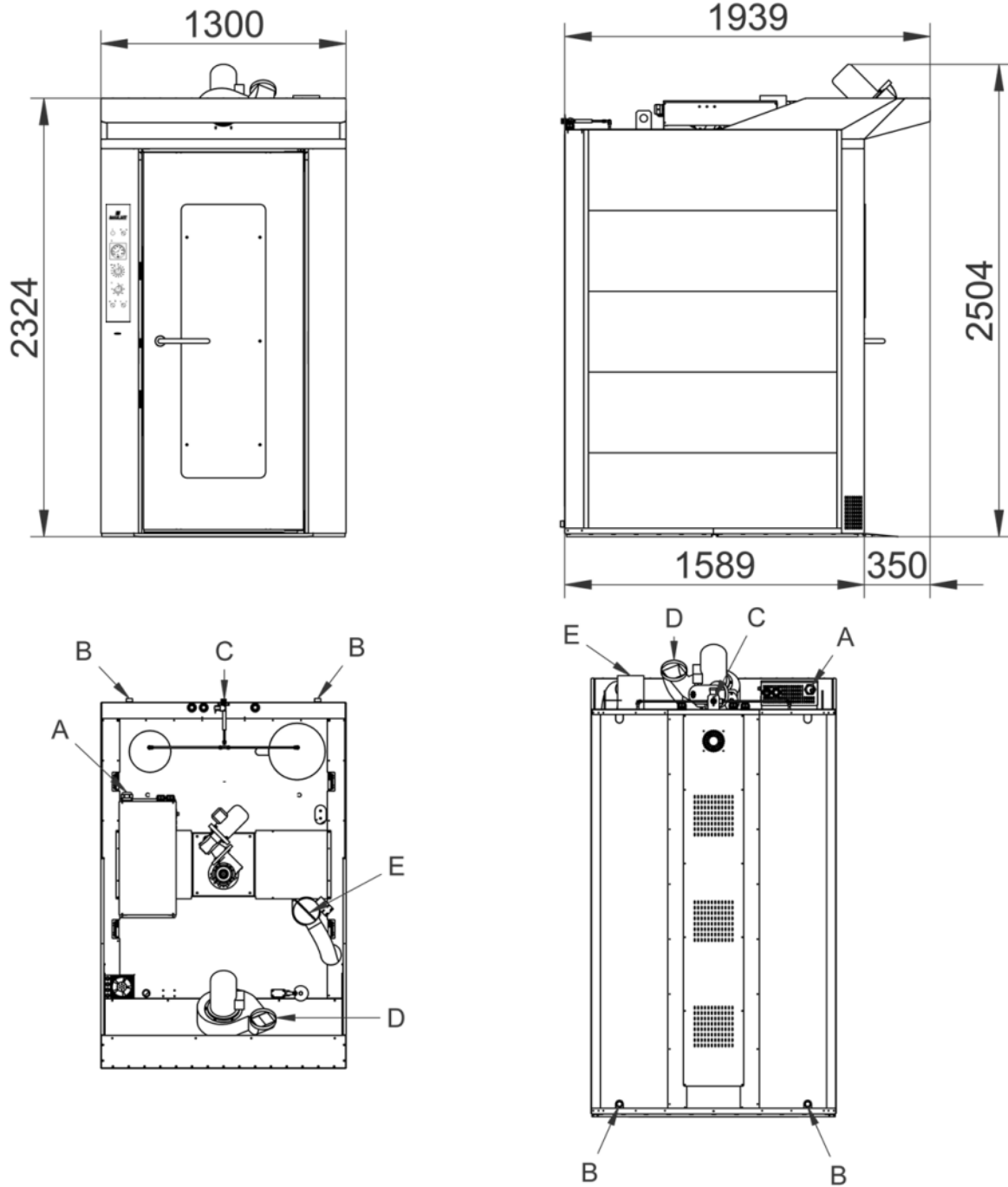

Legend

- A - Power supply inlet
- B - Water discharge 1"
- C - Water inlet 3/4"
- D - Extractor hood discharge
- E - Chamber steam discharge Ø 140

Rotorbake E8 18T Manual

Electrical Supply

Supply and Connections

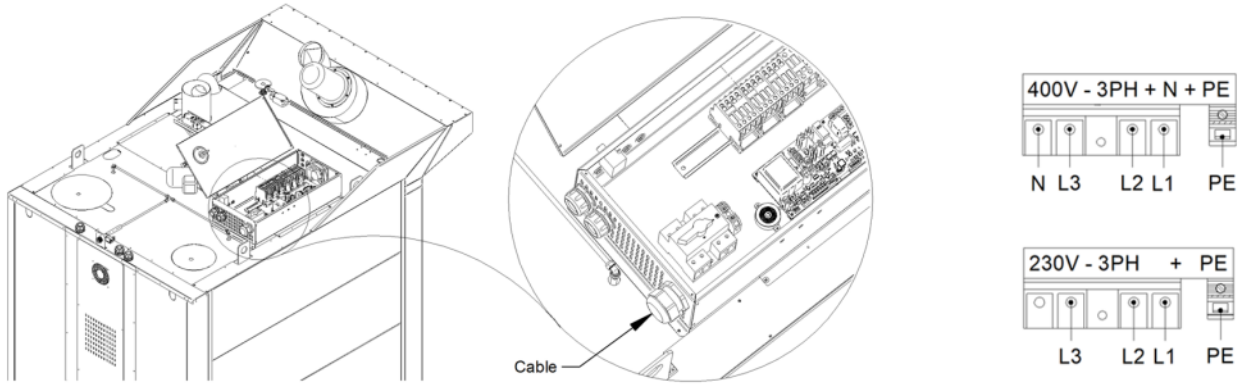

Packaging

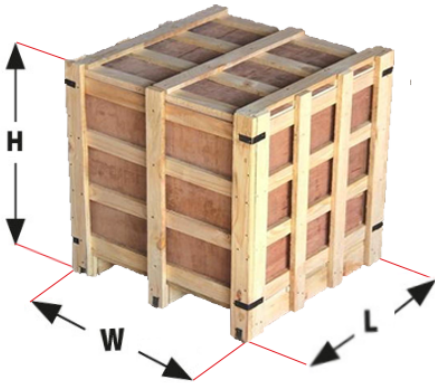

Packing size:	1400 L x 1900 P x 2550 H mm
Net weight:	800 Kg
Gross weight:	875 Kg