



Rotorbake T8 18T Classic

Gas Supply

CODE: 926018250

Trays	18T 60x80 cm (8.6m ²)
Outside dimension	1300 L x 1939 P x 2504 H mm
Tray distance	93 mm
Power	64 kW - 55.000 Kcal/h - Ele. 2 kW
Weight	900 Kg
Max temperature	270° C
Power supply	400 V ~ 3PH + N + PE 230 V ~ 3PH + PE 230 V ~ 1PH + N + PE 50-60 Hz

Equipment

BakeAIR multi-fan system	Double low emissive glass	High-performance thermal insulation
Five fan speeds and semi-static cooking	Five cooking modes	Automatic chimney opening BakeDRY
Program blocking with password	Combustion chamber covered by 7-year warranty	Heat exchanger inside the cooking chamber
CE Certificate	Automatic control of dry/steam balance inside the chamber	Steam control in percentage BakeSTEAM
Automatic control of the cooking level and load	Double steamer RotorBake	Multi-timer function for multiple and mixed cooking
Storage, viewing* and exportation of cooking data (haccp)	Customized programs mode	Manual mode
Preset programs mode	ETL / NSF certification	Automatic preheating
Cooling program	Delayed start programming	Delayed cooking programming
Pre-loaded and online cookbook	Automatic detection and errors report	

Options

S/S external paneling	Double-closing door and double gasket	Rotating platform
Rack automatic lift for Rotorbake	Left door opening	Data logger for USB connection

Rotorbake T8 18T Classic

Gas Supply

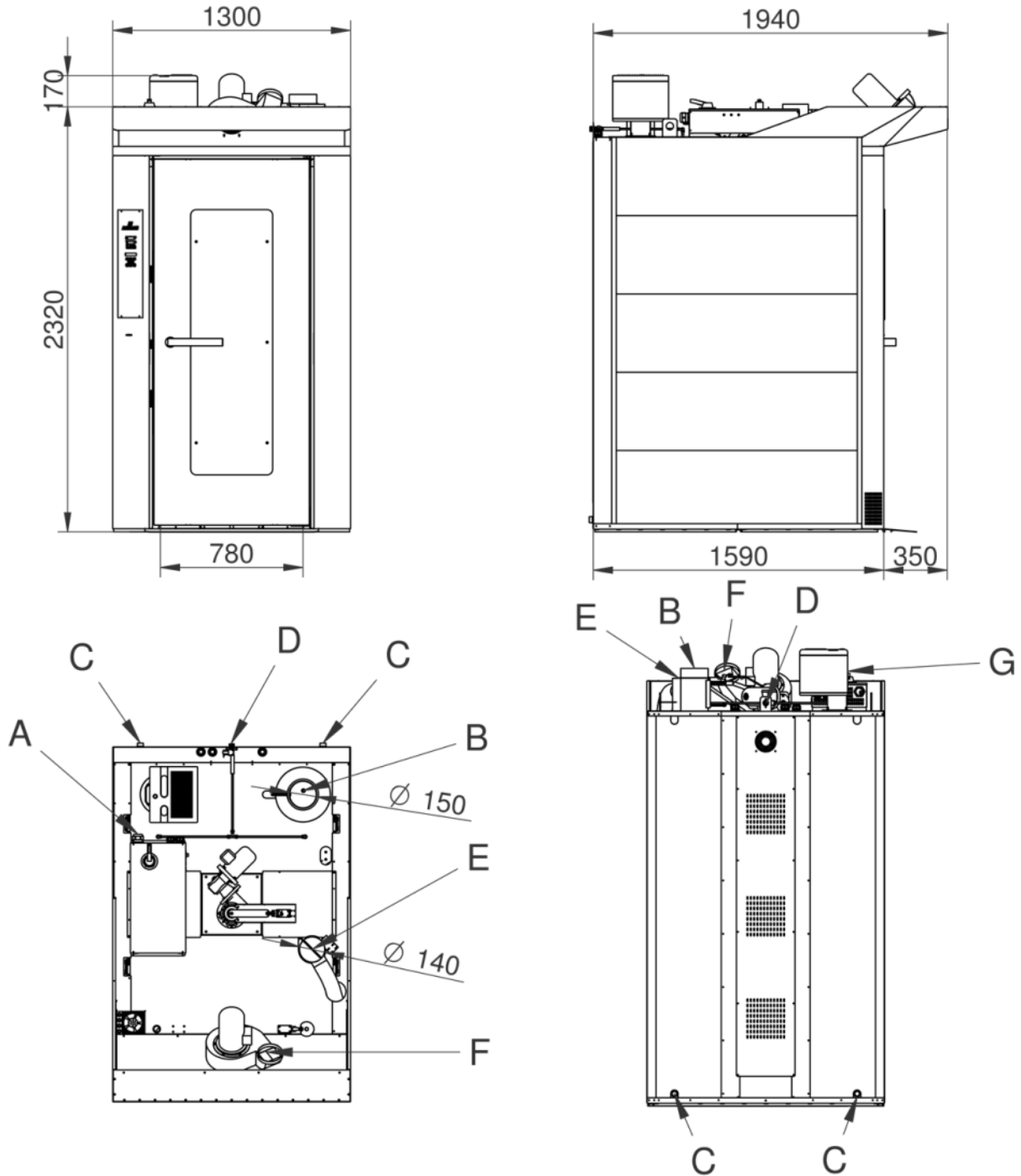

Legend

- A - Electric supply 2 kW - (Pg36)
- B - Ø 150mm Combustion chamber fumes exhaust
- C - Water discharge 1"
- D - Water inlet 3/4"
- E - Chamber steam discharge Ø 140
- F - Extractor hood discharge

G - Burner

Rotorbake T8 18T Classic

Gas Supply

Supply and Connections



Packaging



Packing size:	1400 L x 1900 P x 2550 H mm
Net weight:	900 Kg
Gross weight:	975 Kg