



Snack 4T Digital

Electrical Supply

CODE: 925903240

Trays	4T 60x40 cm
Outside dimension	830 L x 830 P x 570 H mm
Tray distance	75 mm
Power	6,5 kW
Weight	56 Kg
Max temperature	270° C
Power supply	400 V ~ 3PH + N + PE 230 V ~ 3PH + PE 230 V ~ 1PH + N + PE 50-60 Hz

Equipment

BakeAIR multi-fan system	Double low emissive glass	High-performance thermal insulation
Three cooking modes	Rounded baking chamber	Modularity
CE Certificate	Automatic control of dry/steam balance inside the chamber	Steam control in percentage BakeSTEAM
Automatic control of the cooking level and load	Manual steam injection	Manual mode
ETL / NSF certification	Automatic preheating	Automatic detection and errors report
Overlap option		

Snack 4T Digital

Electrical Supply

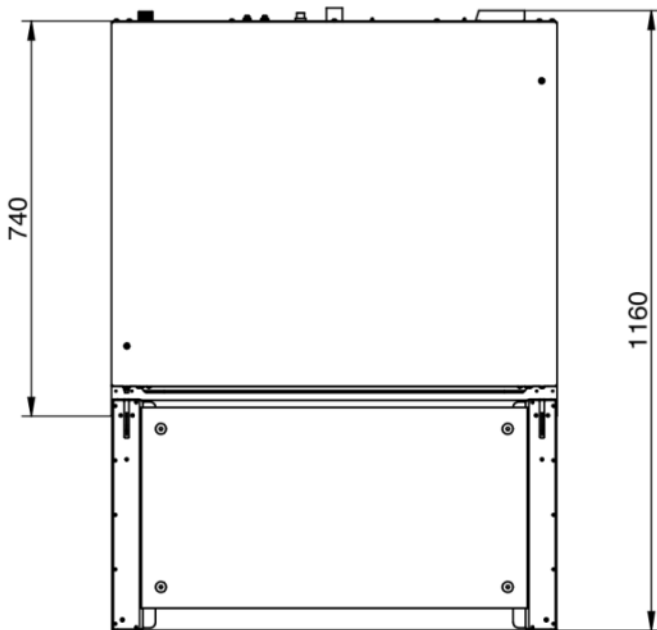
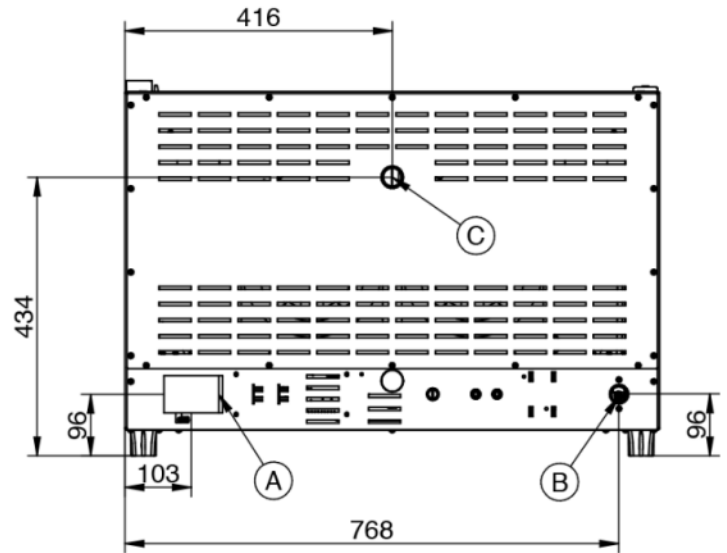
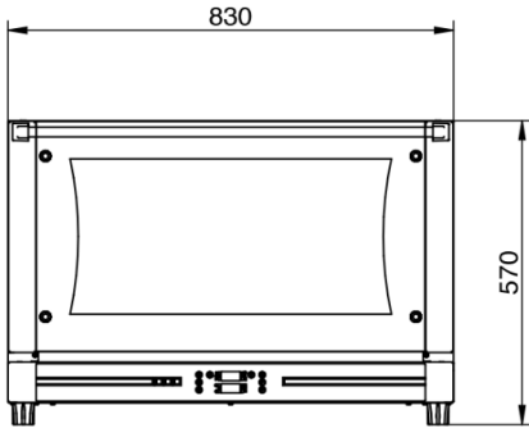

Legend

- A - Electric supply
- B - Water inlet 3/4"
- C - Steam exhaust Ø 30mm

Snack 4T Digital

Electrical Supply

Supply and Connections

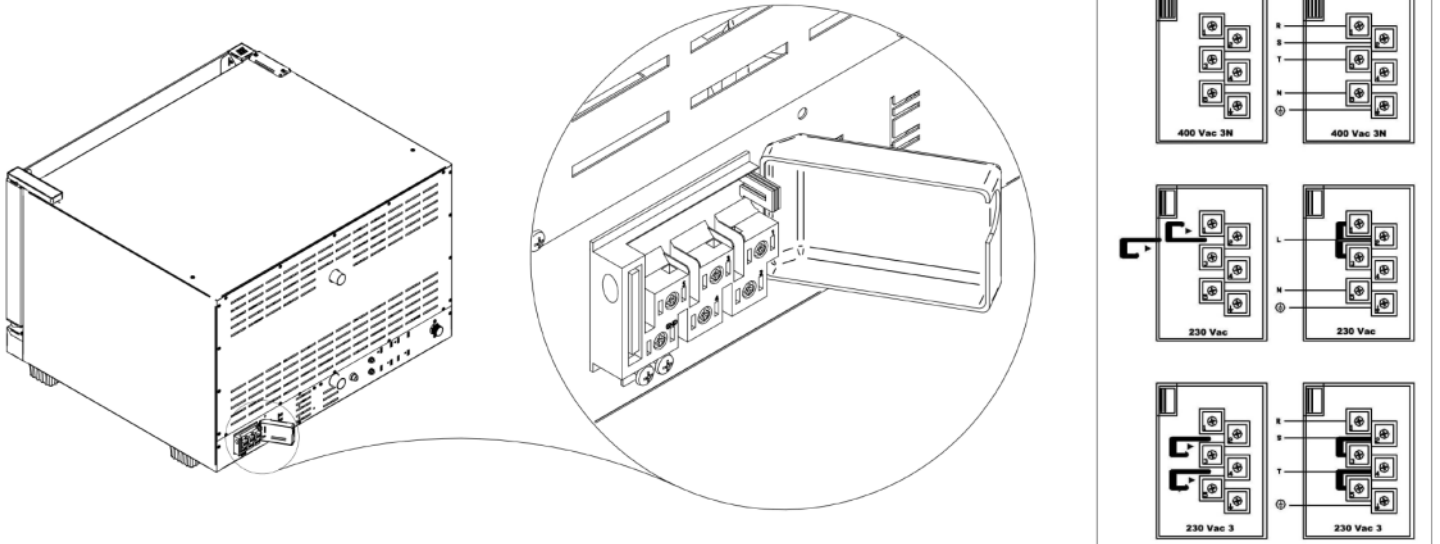

Packaging

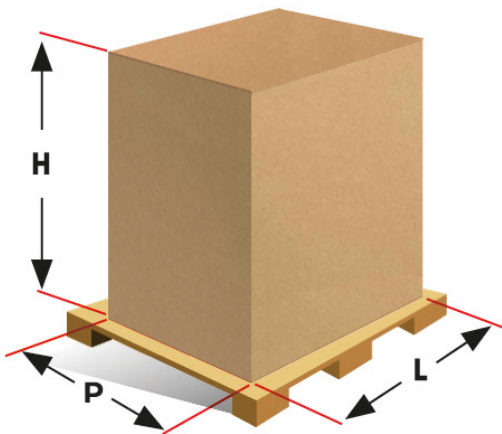

Packing size:	900 L x 900 P x 720 H mm
Net weight:	56 Kg
Gross weight:	66 Kg